

PSMEGA 1

Microcontroller, Single pump control



Options



FS PSMEGA1 Freiluftsäule



Messglocke V4A



Schwimmschalter



Tauchsensoren



Table of contents

- 1.0 General**
 - 1.1 About this document
 - 1.2 Safety
 - 1.3 Identification of information in the operating instructions
- 2.0 Warning and safety information**
 - 2.1 Applications
 - 2.2 Personnel qualifications
 - 2.3 Safety instructions for the operator
 - 2.3.1 Electrical work
 - 2.4 Dangers of non-compliance with safety information
 - 2.5 Operating instructions
 - 2.6 Unauthorised modification and replacement part supply
 - 2.7 Impermissible use
 - 2.8 Transport and storage
- 3.0 General product description, properties and optional functions**
 - 3.1 Product description
 - 3.2 Properties
 - 3.3 Optional functions and/or components
- 4.0 Configuration, control elements and function display**
 - 4.1.0 Symbols on the front panel
 - 4.1.1 Display
 - 4.2 Operating elements
 - 4.3 Function display via light-emitting diodes
 - 4.4 Display
- 5.0 Configuration menu, images and notes on configuring the parameters**
 - 5.1 Table of possible settings.
 - 5.2 Supplements to the individual items in the configuration menu
- 6.0 Error reports in the display, potential errors, assistance**
 - 6.1 Table of possible fault messages
 - 6.2 The settings in the menu cannot be changed
 - 6.3 Motor contactor monitoring
- 7.0 Installation, pneumatic and electrical connection and connection of 3~ and 1~ motors**
 - 7.1 Installation
 - 7.2 Hose attachment
 - 7.3 Electrical connection of power supply and pumps
 - 7.4 Fault signaling outputs
 - 7.5 Input for float switch dry run protection
 - 7.6 Connection examples for the operation of the switching device with float switches
 - 7.7 External level sensor 4 – 20 mA
 - 7.8 Analogue outputs
 - 7.9 Network-independent alarm
- 8.0 Test mode without pump**
 - 8.1 To test the control system without the pumps, please note the following
- 9.0 Technical data**
- 10.0 Norms**
- 11.0 Annex: Status LED – GSM module**
- 12.0 Annex: Terminal connection diagrams, note for the lid and section cover**

1.0 General

1.1 About this document

These operating instructions are part of the product. They must be kept in the vicinity of the product at all times. The careful observance of these instructions is the precondition for the proper use and the correct operation of the product. The operating instructions correspond to the version of the product and the latest state of the underlying safety-related standards.

1.2 Safety

These operating instructions contain essential information that must be observed during the installation and operation. For this reason, it is imperative that these operating instructions are read by both the technician as well as the responsible operator before installation and commissioning. Not only must the general safety instructions be observed that are listed under this main item "Safety", but also the specific safety instructions inserted under the following main points with hazard symbols.

1.3 Identification of information in the operating instructions



General hazard symbol



Hazard due to dangerous electrical voltage



Important information

2.0 Warning and safety information for the installation and commissioning of the control

2.1 Fields of application, proper use

This switchgear has been designed for domestic and municipal sewage, wastewater and rainwater pump stations.



Please note the following in regard to the controlling of pumps operated in an explosive area: The switchgear itself must be installed outside of the explosive area.

The controls are suitable for wastewater submersible motor pumps of the type of protection "d" in zone 1 of the mains. The operating manuals of the pumps must be observed.

When using external 4 - 20 mA level sensors and float switches installed in an explosive area, it will be necessary to use components with the requisite certifications.

It is essential for the switching of three-phase current motors that both the setting of the electronic motor current monitoring as well as for the settings of mechanical motor protection switches that the limit values provided below are adhered to.

Standard version	5,5 KW contactors
Three-phase current 400 V	Max. 12 A
Alternating current 230 V	Max. 12 A

2.2 Personnel qualifications

Personnel tasked with the installation, commissioning and maintenance of the switchgear must hold the requisite qualifications.

2.3 Safety instructions for the operator

Observe the existing regulations governing accident prevention, the VDE specifications and stipulations of the local energy supply company. When opening the device (removal of the panel or terminal cover) or working on the pumps, the control must be switched off from the power supply through the fuse or a separate main switch.

Due to safety reasons, the unused cable glands must be sealed with blanks or blind caps.



HAZARD due to dangerous voltage

When working on the open switchgear,



there is a risk of death from electric shock. For all work on the open device (removal of the cover or terminal cover) or work on the pumps, the control must always be switched off via the backup fuse or a separate main switch and secured against being switched on again. This work may only be carried out by a qualified electrician.

2.3.1 Electrical work



HAZARD due to dangerous voltage



There is a risk of death due to electric shock in all work on open switchgear. During all work on the open device (removal of the panel or the terminal cover) or when working on the pumps, the control must be switched off from the power supply through the fuse or a separate main switch and secured against **reactivation**. To disconnect the battery, pull out the red + plug and isolate the connection with the yellow cap. This work may only be carried out by a qualified electrician.



Beware of moisture!

The device can be damaged by penetration of moisture. When installing, pay attention to the permissible humidity and ensure a flood-proof installation.

For the connection, refer to chapter 6.0 "Connection". The technical information must be observed.

2.4 Dangers of non-compliance with safety information

The non-compliance with the safety information can lead to endangerment for persons and product/system. Non-compliance with the safety information can lead to the loss of all rights for damage compensation.

2.5 Operating instructions

When installing, commissioning and maintaining the switchgear observe the operating instructions. Always observe the limit values cited in the manual.



A fusing on the mains side of max. 3 x 16 A must be performed.

2.6 Unauthorized modification and replacement part supply

Changes to the product are only permissible in coordination with the manufacturer. In the interest of safety, use original replacement parts and accessories authorized by the manufacturer. Using other parts can void liability for the resulting consequences.

2.7 Impermissible use

The operational safety of the product supplied is only guaranteed for proper use as laid out in section 2.1 of the operating instructions. The threshold values specified on the data sheet must be met in all cases.

2.8 Transport and storage

Store and transport the switchgear in such a manner that damage as a result of shock, impact and temperatures outside the range of -30 °C to +60 °C are excluded.

3.0 General product description, properties and optional functions

3.1 Product description

The pump control **PSMEGA 1** is used for the level control of liquid levels. The filling level is optionally determined via dynamic pressure, bubbler system, external sensor (4 - 20 mA) or float switch. The motor contactor directly controls two pumps with a max. output of 5.5 kW. Furthermore, 2 relay contacts are available for the output of fault messages. Control and configuration are extremely easy. Switching points, times and motor current monitoring are configured using a digital potentiometer. All values can be queried on the LC display. LEDs indicate operational states and fault messages. There are further keys available for the Manual - 0 - Auto functions.

3.2 Properties

- Graphical display (display of the level and motor current using a bar graph)
- Thermal and electrical monitoring of the pump
- Manual - 0 - Auto functions
- Pump deactivation via switch-off point and overrun
- Acknowledge button
- Electronic 3~ monitoring of the motor current
- Runtime monitoring
- Rotating field and phase failure control (activate in the menu)
- Forced switch-on of the pump
- Variable staggered start (delayed switch on)
- Internal audible alarm
- Collective fault alarm fixed voltage and potential-free
- High water alarm potential-free
- Memory, number of pump starts
- Operating hours counter
- Ammeter
- Pump change
- Forced switchover
- High interference immunity
- Easy to operate
- ATEX mode
- Service mode
- Input for float switch dry run protection
- Analogue outputs 0-10 V and 4-20 mA
- Fault memory stores the last 4 faults

- Automatic display illumination switch off (after 30 seconds) can be disabled
- Mains-independent alarm (9 volt battery, not included in delivery)
- In manual operation it shuts off automatically after a running time of 2 minutes
- Level detection optionally via internal pressure transducer, external 4 - 20 mA sensor or float switch
- Measuring range of the external 4 - 20 mA level sensor can be selected via the menu in the range of 0 - 10 m
- Connection to remote control systems via digital and analogue inputs and outputs
- All settings and various error messages are saved in non-volatile memory
- All functions of the previous version have been maintained
- Spare inputs for telecontrol module, timer switch or other (are only integrated in the program when required)
- parameters can be saved on an SD card and imported again
- an event log is written on the SD card

NEW:

- Monitoring of all three phases
- Motor contactor monitoring

3.3 Optional functions and/or components

(only included in delivery if specified specifically in the order)

- External locking (the dry run protection is omitted here)
- Additional pressure sensor for redundant flood alarm with a switching on of the pumps
- GSM modem
- RTU-MOD bus
- Bluetooth module
- Mains-independent alarm
- With the **PSMEGA 1-E** version, the control is also optionally available with a motor protection switch according to EN 60947, main switch according to EN 60947, ground fault circuit interrupter or EX barrier (not together with motor protection switch) available.

4.0 Configuration, control elements and function displays

4.1.0 Meaning of the symbols on the front panel



LED red – Fault / high water alarm



LED yellow – pump / overrun operation



LED green – Manual / automatic operation



LED blue – Status GSM



Pushbutton switch – Manual operation



Pushbutton switch – Off



Pushbutton switch – Automatic operation



Pushbutton switch – Selection / acknowledgement



Rotary knob – Display

4.1.1 Display

All information and settings can be queried using the digital potentiometer *display*. If a setting is to be changed, the regulator is adjusted until the corresponding setting appears on the display. Now press the *select / cancel* button. The value last saved will start to blink. The digital potentiometer *display* can now be used to change the setting. Quick turns will change the values more rapidly, while slow turns make it possible to make more precise changes. Once the desired value has been reached, use the *select / cancel* button to confirm. The value will stop blinking and be stored. Check all values prior to commissioning. The display will automatically return to the default setting after 20 seconds.



The operating hours and pump starts are counted continuously, it is not possible to adjust or reset them.

4.2 Operating elements



Pressing the digital potentiometer will query all settings as well as error messages, operating hours, number of pump starts and motor current. Moreover, the settings are performed using the digital potentiometer. If the knob is not moved for more than 20 seconds, then the display will jump back to the default setting. (see above, Configuration chapter)



Pressing this button will confirm the errors overcurrent, pump without load and thermal error 2 after removal of the cause. In the event that an error should continue to be present, then only the common error report relay and the piezo buzzer will be shut off. This also applies to all other errors and the high water alarm. Settings can still be changed using the button.



Pressing this button will manually put the pump into operation. The green LED will blink. If the pump is being operated in the manual function, then it will automatically shut off after 2 minutes and the green LED will flash irregularly.



The automatic and manual operation are shut down using this button. The green LED is off.



The pump is switched based on the level. The green LED is lit continuously.



If power is interrupted during manual mode, then the control system will return to the automatic mode. The operation modes "Auto" and "0" are stored in non-volatile memory.

4.3 Function display via light-emitting diodes



LED - red = Fault, high water alarm



LED - solid yellow = The pump is in operation
LED - flashing yellow = The pump is in operation via the overrun function



LED - solid green = Automatic mode
LED - flashing green = Manual mode
LED - irregular green flashing = Manual mode has shut off after 2 min



LED - blue: (Function only with module)
Continuous flashing = The board is in the initialization Phase
Continuous light = The board is initialized and has connected to the provider
Single Flash, Long break = The modem does not answer
Double Flash, Long break = The SIM card cannot be found
Triple Flash = The GSM signal strength is too weak

4.4 Display



In the upper area of the display, there is a bar graph for the level (L) and two bar graphs for the current of the pumps (I). In the display's basic setting, the level and the operating hours are additionally displayed in numbers below the bar graph displays. If the pump is in operation, the motor current will be displayed. If any disruptions occur, then they will be displayed alternately on the display's bottom line.

4.4.1 Automatic deactivation of the background lighting:

If no further settings are performed on the device, the background lighting switches off automatically after 30 seconds. As soon as the rotary switch or one of the pushbutton switches is actuated, the background lighting switches on again. This function can be disabled via the menu and then the background lighting remains switched on.

5.0 Configuration menu

5.1 The following table shows the configuration possibilities. The display's top line shows the option, the bottom line is the value that can be changed.

1. line of Display	Option for Setting	Explanation
<i>Last fault 1-4</i>	Delete value	The last 4 errors remain stored in the non-volatile memory and can be deleted in the position "Last fault 1" using the acknowledge pushbutton.
<i>Level ON</i>	0 – 100 (200) cm	The value determines start level of pump
<i>Level OFF</i>	0 – 100 (200) cm	The value determines stop level of pump
<i>High water level</i>	0 – 100 (200) cm	Once predetermined value is exceeded, the collective fault report relay and the high-water relay are activated
<i>Running time max</i>	0 – 60 Min.	The value 0 deactivates this function. If the value is set between 1-60 min. the pump shuts off if the set operating time has been exceeded without interruption
<i>Start delay</i>	0 – 900 sec.	After a power outage the pump will only start after the pre-set time is over. The display will show the remaining time.
<i>Stop delay</i>	0 – 180 sec.	After the Stop level is reached, the pump will keep running until the pre-set time is over.
<i>Current limit</i>	0.3 – 16.0 A	If the pump exceeds the set power intake for a certain time, it shuts off. The display shows: Overload. The pump will only be re-activated after the button "Quittung" has been pressed
<i>Inspection All xxx Days</i>	Is deactivated, 90, 180 and 365 Days	The setting can only be changed by the service personnel.
<i>Force activation</i>	Is deactivated, 0 – 10 sec.	Is activated = If the pump has not been activated for 24 hrs, it will automatically run for duration of the set time.
<i>Acoustic alarm</i>	Is deactivated, Is activated	Is activated = In case of a malfunction the internal piezo-buzzer will sound
<i>Intermitt. alarm</i>	Is deactivated, Is activated	Is activated = The fault information-relay will be synchronized Instead of a flashing light it is possible to use a more economic steady burning light
<i>Thermal fault 1</i>	Is deactivated, Is activated	Is deactivated = There is no bimetallic contact (alarm contact) connected to terminal 12, 13.
<i>Rot. field fault</i>	Is deactivated, Is activated	Is activated = in case the phase sequence is wrong or if L2/L3 have been missed an alarm will be triggered and the pumps cannot be activated.
<i>3~ Monitoring</i>	Is deactivated, Is activated	Is activated = The motor current of all 3 phases is monitored. Is deactivated = Only L1 is monitored, 230 V operation
<i>Light off autom.</i>	Is deactivated, Is activated	If no further settings are actuated on the device, the background lighting switches off automatically after 2 minutes.
<i>ATEX - Mode</i>	Is deactivated, Is activated	Is activated = If no liquid can be measured by the level sensor the pumps cannot be activated. This is valid for the Manual mode as well as the Forced activation and the remote-control systems.
<i>Service - Mode</i>	Is activated, Is deactivated	Is activated = All settings can be adjusted Is deactivated = Settings are shown but cannot be adjusted
<i>Level Control</i>	Intern. converter Floating switch 4 – 20 mA Interface	Determination of level by impact pressure or air supply. Determination of level by floating switch Determination of level by external sensor (4 – 20 mA)
<i>Bar Level max.</i>	0 – 1000 cm	The resolution of the bar graph display for the level can be adjusted. The max. value corresponds to the full deflection of the display..
<i>Bar Current max.</i>	0 – 1000 cm	The resolution of the bar graph display for the level can be adjusted. The max. value corresponds to the full deflection of the display..
<i>20mA =>Level</i>	0 – 1000 cm	The effective range of the external level sensor can be adjusted
<i>Language</i>	da-de-en-fr-it-es-pt- nl-no-pl-cz	The displayed language can be adjusted

5.1.1 Menu items factory settings, data import and export

Menüpunkt	Erklärung
Preferences reset	All settings can be reset with this function. Attention: Pump starts, operating hours, error memory and maintenance status are preserved.
FatFS: Filename	An input menu can be opened here to assign a file name. Now the current settings and log files can be saved under this file name.
FatFS: Read	The file with the setting parameters is read by the SD card
FatFS: Write	The file with the current parameters is written by the SD card.
FatFS: Log	The operating hours, pump starts and error notifications are transferred to the memory card.

5.2 Supplements to the individual items in the configuration menu

5.2.1 Start Delay

The delay configured will only be active after a loss in power (staggered start in projects). For each further start, the pumps will immediately turn on when they are triggered via the level.

5.2.2 Lowest level configurations (On/Off)

If a switch-on point lower than 5 cm is selected, then the software will automatically use 5 cm as the switch-on point. If a switch-off point lower than 3 cm is selected, then the software will automatically use 3 cm as the switch-off point. This also applies to starting overrun time, which will then start at 3 cm. This is necessary for the safe operation of the switchgear system.

5.2.3 Stop Delay, Overrun

Overrun facilitates draining below the level sensor, e.g. for dynamic pressure systems.

5.2.4 Runtime monitoring, Running time max.

The menu can be used to access the item maximum runtime. In the default setting, this value is set to zero, i.e. the function is disabled. When a value of 1 – 60 minutes is set, then a deactivation of the pump occurs when the pump runs without interruption for longer than the set value. Moreover, an alarm will be triggered and a corresponding error report will be shown on the display. The pump will not run again until the error has been confirmed. The runtime monitoring applies to both the automatic as well as the manual mode.

5.2.5 Current monitoring (max. current)

The nominal current of the corresponding pumps can be set immediately. The software in the control adds a certain percentage to the set value to compensate tolerances. The triggering occurs according to an I^2 / t function and with this, the increased initial current of the pump is taken into account.

5.2.6 Inspection

The **PSMEGA 1** can issue a message on the display on when servicing is to be performed. The configuration possibilities are 90, 180 or 365 days. The function can also be turned off at this point in the menu (factory settings).



Only service personnel are able to change or reset the settings.

5.2.7 Th. fault 1, Th. fault 2

For pumps whose temperature monitoring consists of only one bimetallic contact per pump, thermal error 1 can be deactivated accordingly in the menu. Thermal error 2 cannot be turned off in the menu.

5.2.8 Error memory, Last fault

The last 4 errors that occurred remain stored in non-volatile memory and can be retrieved in the menu under "Last fault". Caution Last fault 1 is the last fault that occurred. If "Last fault 1" is called up in the menu, the last errors can be deleted from the memory with the acknowledge button.

5.2.9 Rotary field error

The rotary field monitoring monitors both the phase sequence as well as the lack of a phase. The pumps are locked in the event of a phase error, an alarm is issued and the message "Rotary field error" appears on the display. The rotary field monitoring can be activated and deactivated via the menu.



The rotary field monitoring must be switched during the operation of 1~ motors.

5.2.10 3~ monitoring

Display, evaluation and monitoring of the motor current on all three phases. In the event of the deactivation of the 3~ monitoring, only a single phase (L1) is monitored. This enables the operation of 1~ motors. (See page 10, point 7. Electrical connection)

5.2.11 ATEX – Mode

ATEX mode has to be activated for pumps implemented in EX zones. ATEX mode impedes the pumps from being turned on via manual function, via forced switch-on or via remote control system until the switch-off point is met. If the pumps are started via the overrun time or manual function while the switch-off point is exceeded, then draining can occur below the switch-off point. The manual function will be automatically interrupted after 2 minutes. When the ATEX function hinders pumps from turning on, the display will show the report "ATEX: Level below switch-off point."

5.2.12 Service – Mode

The default setting is for service mode to be activated, i.e. all setting can be changed. When the service mode is turned off in the menu, the settings can only be queried using the digital potentiometer.



When the service mode is deactivated, no settings can be changed other than the local language.

5.2.13 Level control

It can be selected whether the control system will run via the internal level sensor (dynamic pressure, bubbler system), an external 4 - 20 mA level sensor or a float switch. The input for the high water alarm (**terminal 19 / 20**) is always active and can be used as a redundant system. When using external 4 - 20 mA level sensors and float switches installed in an explosive area, it will be necessary to use components with the requisite certifications.

5.2.14 20 mA => Level

This setting adapts the switch points and the display of the level to a connected external 4 - 20 mA level sensor. The processor converts the input signal such that the correct level is displayed. When the measurement range for the 4 - 20 mA sensor is changed in the configuration menu, the switch points will have to be re-configured, as they will have changed determined by the system. Thus, the correct order will always be to first configure the sensor's measurement range and then the switch points. The corresponding regulations must be observed for the use in the EX zone, i.e. a 4 - 20 mA sensor with corresponding certification and a matching EX barrier. If the switch points are outside the level sensor's configured range, then the message "Check switching points" will be shown.

5.2.15 Bar Level max. / Bar Current max.



In order to allow for a practical resolution of the bar graph display, the maximum value of the respective display can be set here. If AUTO is selected in the menu item, the maximum value of the respectively set level or the max. current will be used automatically.

5.2.16 Local language

The scope of delivery includes German / English / French / Italian / Spanish / Portuguese / Dutch / Swedish / Norwegian / Danish / Polish / Czech. The country language can also be changed when service mode is deactivated.



5.2.17 Menu items data import and export

The **PSMEGA 1** offers the option of writing and reading configuration files:

Menüpunkt	Erklärung
<i>FatFS: Filename</i>	An input menu can be opened here to assign a file name. Now the current settings and log files can be saved under this file name.
<i>FatFS: Read</i>	The file with the setting parameters is read by the SD card
<i>FatFS: Write</i>	The file with the current parameters is written by the SD card.
<i>FatFS: Log</i>	The operating hours, pump starts and error notifications are transferred to the memory card.

5.2.18 FatFS: Filename

At this point, the file name is assigned for the configuration and log files. The file name **PSMEGA 1** is preset. A code page can be opened by pressing the select/ acknowledge button. A character can be selected with the knob and accepted with the select/acknowledge button.

-  Delete characters
-  Save the file name and exit the menu
-  Leave menu without saving the changes

5.2.19 FatFS: Read

By pressing the select/acknowledge button, a configuration file with the set name is read from the memory card and the settings are taken over. If there is no corresponding file on the memory card or if no memory card is inserted, a corresponding error notification will appear in the display.

5.2.20 FatFS: Write

By pressing the select/acknowledge button, the current settings are written on the memory card. The configuration file receives the previously entered name. If a memory card is not in the holder, a corresponding error notification will appear. If a file with the same name is already on the card, a prompt will appear asking if the file should be overwritten.

5.2.21 FatFS: Log

By pressing the select/acknowledge button, a log file is written on the memory card with the current operating hours, pump starts and errors. The log file can be read with any text editor.



Memory card size up to **64 GB!**

6.0 [Fault messages, possible malfunctions, corrections](#)

6.1 [Fault messages on the display](#)

Message on Display	Possible cause	Correction
<i>Thermal Fault 1</i>	The controller contact of the according pump initiates.	If the pump in use does not come with the required thermal motor protection contact the mode needs to be deactivated in the menu (compare to 5.2.7. Thermal Fault 1, Thermal fault 2). Check the pump. If it is plugged, clean out the foreign matter. Check the motor for sufficient cooling (dry run).
<i>Thermal fault 2</i>	The limiting contact of the according pump initiates.	If the pump in use does not have the required thermal motor protection contact every pump that is used needs to be bridged. (compare to 7.3.3 Thermal motor protection contact). Check the pump. If it is plugged, clean out the foreign matter. Check the motor for sufficient cooling (dry run). After the pump has cooled off, push the button "Quittung" in order to unlock the pump.
<i>Pump off</i>	Phase 2 is missing or the control unit is being operated without charge.	Check feed-in, pump cables, and pump
<i>High-water-Alarm</i>	The level has exceeded the flood setting	Check pump for mode or high-water level
<i>High-water switch</i>	Contact for the high-water switch has closed	Check if pump/ floating switch are functioning
<i>Reverse signals start/stop level</i>	The settings for start and stop levels interfere.	Check level settings
<i>Reverse signals start/flood level</i>	The settings for high-water alarm and start level interfere	Check settings for level
<i>Runtime error</i>	Pumps run without interruption for longer than the time set.	Check function of pump
<i>Floating switch malfunction</i>	Validation of floating switches, wrong order	Check if floating switch is functioning and check if it is connected to power correctly
<i>Dry run protection activated</i>	Contact for dry run protection has been activated	Check functioning of pump / floating switch
<i>Interface < 3 mA</i>	Signal of external level sensor lower than 3 mA	Check level sensor, Ex-barrier, and electrical connections
<i>Please check control settings</i>	The effective range of the external level sensor has been changed. The level settings lie outside the effective range.	Check settings for level
<i>Rotating field</i>	One or two phases are missing, or rather the rotating field is not correct	Check if all 3 phases are adjacent and if the rotating field is correct.
<i>ATEX: level less than stop level</i>	The ATEX mode has been activated and the level lies below the stop level of the chosen pump.	Before being able to activate the pumps, the level in the Ex-area needs to rise over the stop level of the pump. As long as the pumps are not in the Ex-area, the ATEX mode can be deactivated in the menu.

6.2 The settings in the menu cannot be changed

Check in the menu whether the service mode has been activated.

6.3 Motor contactor monitoring

When the contactor is not requested by the control and nevertheless a current is measurable on one or more phases, then the error message "Contactor error" will appear in the display and the audible alarm will sound.

7.0 Installation, electrical connection

7.1 Installation

The control unit **PSMEGA 1** is placed in a control box that measures 250 x 225 x 115 mm (H x W x D) with screw fittings and air connection). There are 4 drill holes on the switch cabinet for mounting, which become visible when the cover is opened.

7.2 Hose attachment

As standard, a hose screw connection 8/6 mm is delivered for the hose connection. Optionally, the switching device can be delivered with other hose screw connections. The subsequent replacement of the hose connection is also possible. The hose screw connection must feature an internal thread of G1/8" towards the unit. During replacement, it is important that a 14 mm spanner is used to secure the corresponding nut. In any case, the threaded connection must be used in combination with a suitable sealant.

7.3 Electrical connection power supply and pumps

The electrical connection must be performed by a qualified electrician in accordance with the applicable VDE regulations.



HAZARD due to dangerous voltage!



Improper handling of electrical work may result in a risk of death due to electrical voltage!

A time-lag fusing on the mains side of max. **3 x 16 A** must be performed.

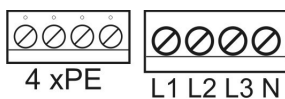

Mains connection (3~) PE, L1, L2, L3, N (image 1a in the annex)

The connecting terminals have been designed for a max. cable cross section of 4 mm². Attention must be paid that a right rotary field is created. The terminals are labelled L1, L2, L3, N. The PE terminals are implemented as a brass rail.

7.3.1 Connection of the pump:

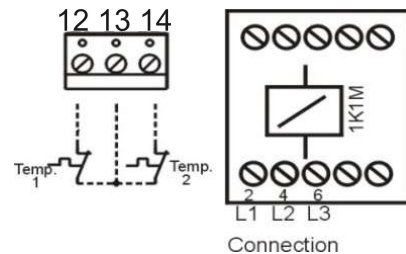

The connections L1 L2 L3 of the pump are directly attached to the motor contactor. The protective earth conductor is connected to the remaining PE terminal. The bimetallic contact, which unlocks the pump after it has cooled down, needs to be connected to terminal 12/13; the bimetallic contact that unlocks the pump after pressing the "Quittung" button needs to be connected to terminal 13/14 on the upper circuit board. (In case Temp.1 is not being connected, *thermal fault 1* needs to be deactivated in the menu).



To operate 1 ~ motors (230V AC) a bridge between input terminal N an L3 are necessary.

7.3.2 Power supply of the pumps (1~)

The pump is connected to contactor **T1 = L** and **T3 = N**

7.3.3 Protective winding contacts

Regulator contact **Temp 1 / terminal 12/13**
The pump is released automatically after cooling down.

Limiter contact **Temp 2 / terminal 13/14**
The pump is only released after actuation of the acknowledge push button.



This temperature monitoring must be used for pumps located in the **EX area**.

When Temp. 1 is not used, then the function must be disabled in the menu (see above chapter 5.2.7.).

When Temp. 2 is not used, then a wire jumper must be used from terminal 13 to 14.

For pumps, in which the bimetallic contact has been switched in such a manner that this directly interrupts the current of the pump, the message "**Without load**" appears, when the bimetallic contact has been triggered. The pump can only be taken into operation again following the acknowledgement.

The inputs of the controls for the thermal errors are designed for the evaluation of the protective winding contacts. Separate evaluation devices must be used for motors with embedded temperature sensors (e.g. PTC resistor) as thermal protection.

7.4 - 9 Electrical connection of the fault signalling outputs and the signal inputs (image 2 annex)

7.4 Fault signalling outputs

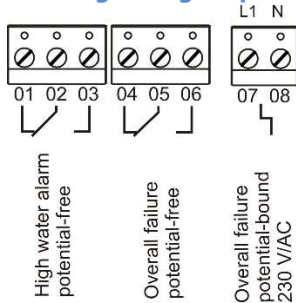

Terminal 1 / 2 / 3 = High water alarm, potential-free, 2 / 3 closed in case of alarm.

Terminal 4 / 5 / 6 = Overall failure, potential-free, 5 / 6 closed in case of alarm

Terminal 7 / 8 = Relay output for every failure potential-bound. In case of an alarm there are 230 V/AC adjacent (this port is protected by a micro-fuse 1 A T).

7.5 Input for float switch dry run protection

Terminal 10 / 11 = Dry run protection
Polarity of the terminals: 10 = positive and 11 = negative (24 V/AC 10 mA)

When a float switch is connected to terminal 10-11, then it can be prevented that the cutting unit or impeller appears from the medium. The dry run protection is active in both automatic as well as manual operation.

 For use in the **EX zone**, the corresponding requirements must be complied with.

This input is optionally also used for locking the unit when a specific program has been agreed upon.

7.6 Connection examples for the operation of the switching device with float switches

The display shows which switch is connected. Closing contacts must always be used. "Float switch" must be selected in the menu under "Level control". The input for the high water alarm (terminal 19/20) is always active.

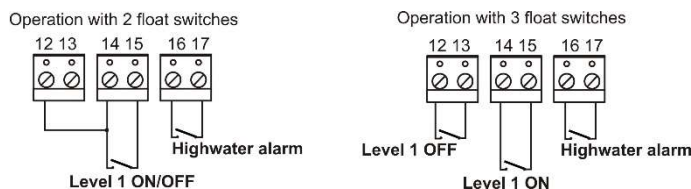

Operation with a common line of float switches is not possible.

 For use in the **EX zone**, the corresponding requirements must be complied with.

7.7 External level sensor 4 – 20 mA

"4 - 20 mA interface" must be selected in the menu under "Level control". An external sensor 4 - 20 mA two-wire technology (passive sensor) can be connected to the terminals 25 (-) and 26 (+). The sensor is supplied with a stabilized direct voltage of approx. 24 volt. In the delivered state, the measuring range of the level sensor is set in such a manner that it matches the measuring range of the internal pressure sensor. In the event that the level sensor should be connected with a different measuring range, then the corresponding setting must be changed in the menu (see section 5.2.14). The output is active, i.e. the sensor is supplied with voltage by the control.

 For use in the **EX zone**, the corresponding requirements must be complied with.

In the event of the connection of an active sensor (external voltage supply), the positive line of the sensor must be connected to the negative terminal (25) of the input. The negative line of the sensor must be connected to the common internal earth (negative), terminal 28 or 30 (negative of the analogue outputs).

7.8 Analogue outputs

The analogue outputs are intended for the connection to the control system. The signals change proportionally to the level.

- 0 - 10 V = Terminal 27 (+) and 28 (-) resistant up to max. 10 mA
- 4 – 20 mA = Terminal 29 (+) and 30 (-) burden max. 250 ohm

The length of the lines for the analogue outputs must not exceed 1.50 m, and must not be laid along with lines prone to interference.

7.9 Network-independent alarm:

By using a 9V block battery, a mains-independent alarm message can be issued in the event of a power failure. A continuous acoustic signal is emitted as an alarm which cannot be acknowledged, even if the acoustic alarm has been deactivated in the menu. To deactivate, the battery must be disconnected.

Please pay attention to the correct polarity when inserting the battery!

To ensure that it functions properly, the battery must be fully charged before being inserted or it must be charged in the switchgear for 24 hours.

 **Attention!** Under no circumstances should normal batteries be used.

The following batteries may be used:

Nickel metal hydride accumulator (NiMH)

8.0 Test mode without pump

8.1 In order to test the control unit without pumps the following needs to be considered

- It is sufficient to connect N1 and L1
- Unless the motor current protection is set to 0 A, the message "L pump off" will appear
- Terminals 13 / 14 need to be bridged, otherwise the message "Thermal Fault 2" will appear.
- Thermal fault 1 need to be deactivated in the settings menu, otherwise the message "Thermal Fault 1" will appear.

9.0 Technical data

Operating voltage: 3 ~ 400V (L1, L2, L3, N, PE)
 Frequency 50 / 60 Hz
 Control voltage: 230V / AC

Power consumption:
 (Contactor activated) < 7,5 W
 Power consumption in idle state < 5 W
 Max. installed power $P_2 \leq 5,5$ KW

Range of the electrical motor current monitoring 0,3 – 16 A
 (Here, the limit values featured in the table under point 1.1 of the safety instructions must be adhered to)

Alarm contact 230 V 1 A
 Alarm contact potential-free 3 A
 Housing: ABS
 Protection class: IP 54
 Pressure range (internal sensor): 0 - 1 mWs (0 - 2mWs Option)

Transport and storage temperature - 30° bis + 60°C
 Operating temperature range: - 20° bis + 50 °C
 Dimensions: 250 x 225 x 115 mm (HxWxD)
 Dimensions with cable gland and air connection

Fuse: 5 x 20 1AT (alarm output)

Voltage supply for 4-20 mA sensor and float switch

24V / DC
 2 x M25 x 1,5
 1 x M16 x 1,5
 3 x M16 x 1,5 blind plug

Hose attachment: 6/8 mm
 (Other hose connections are available on request.)
 Software version: Ver. 0.3



When opening the device (removal of the panel or terminal cover) or working on the pumps, the control must be switched off from the power supply through the fuse or a separate main switch.

Technical specifications subject to modification!

10.0 Norms:

Applicable EC directives:

EC Low Voltage Directive 2014/35/EC
 EC Electromagnetic Compatibility Directive 2014/30/EC

Applied harmonised standards, in particular:

EN 60204 - 1: 2014
 EN 60730 - 1: 2016
 IEC 61000 - 6 - 3: 2006
 IEC 61000 - 6 - 2: 2016

11.0 Annex:

Status LED – GSM module:

Flashing constantly = The board is in the initialisation phase

Illuminated constantly = The board has initialised and has connected with the provider

Flashes once briefly, then extended pause = The modem is not responding

Flashes twice briefly, then extended pause = The SIM card has not been found

Flashes three times briefly = The GSM signal strength is too weak

12.0 Annex: Terminal block wiring diagrams

Terminal connection of 3~ motors

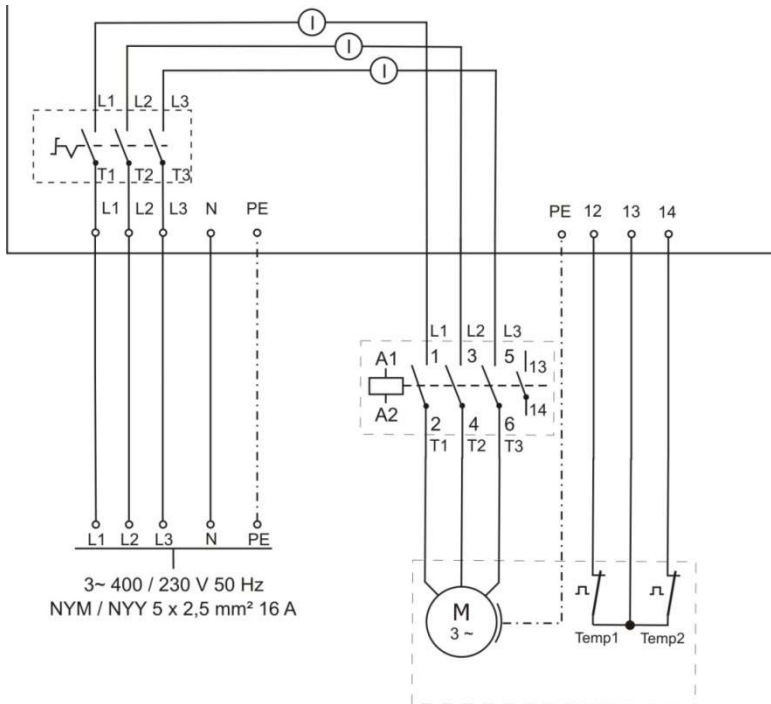

Terminal connection of 1~ motors

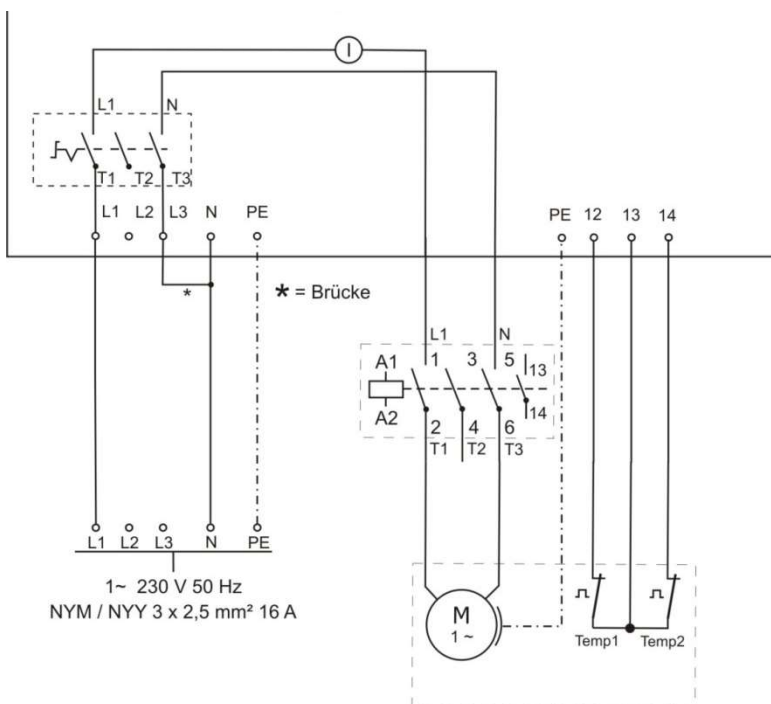

Caution! When connecting 1~ motors the maximum connected load is **2,4 KW**.

Relay outputs, signal inputs and analogue outputs

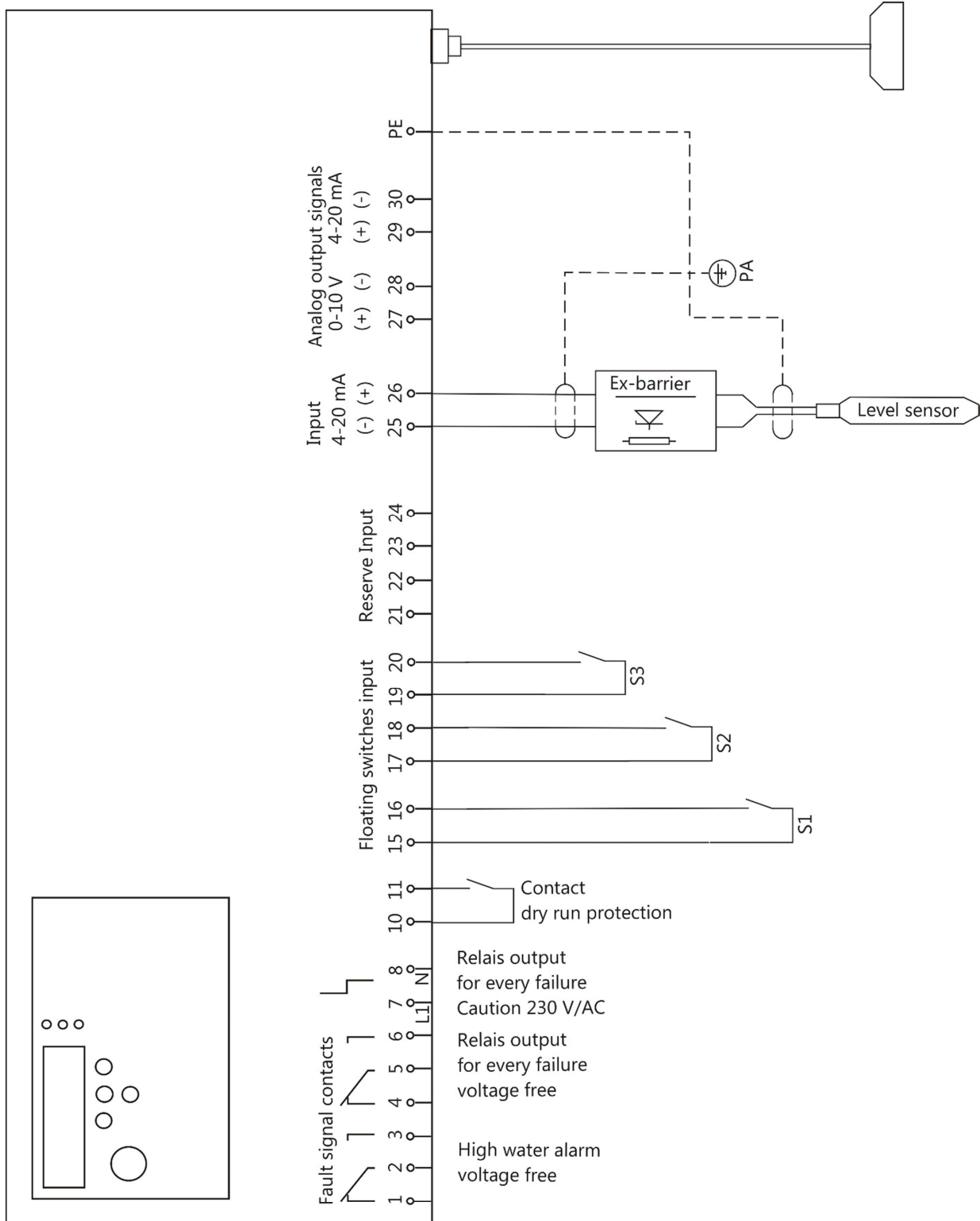

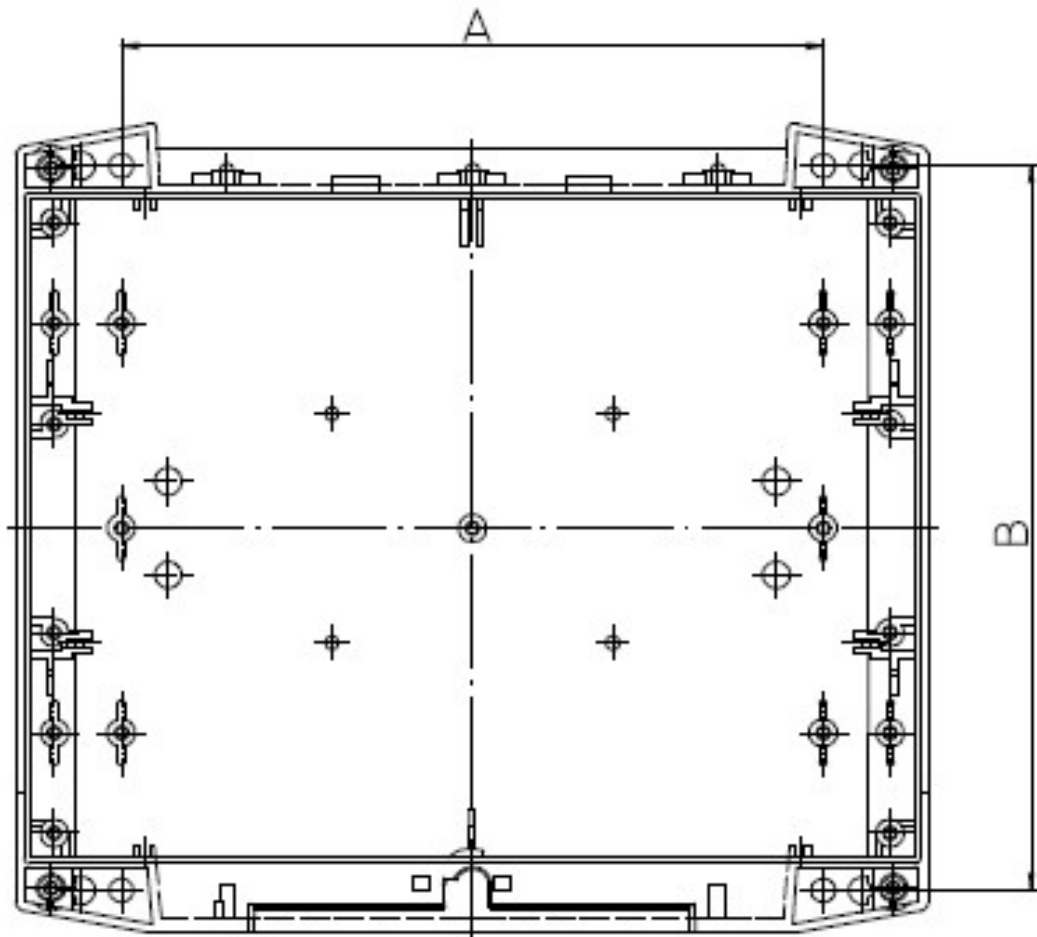

A=180 mm

B=180mm

$\varnothing = 5,0\text{mm}$

weitere Produkte



PSMEGA1



Messglocke V4A



LESA Micro-Kompakt



PLC TOUCH Grossanlage



LESA- GSM 8



**Kompaktschaltschrank
LCD2 - System Metall**



**Kompaktschaltschrank
mit Noteinspeisung
und EVU-Anschluß**



**PLC TOUCH-System
Kompaktschrank**

- * Pumpensteuerungen
- * Pumpenschaltmodule
- * Alarmmodule
- * GSM-Module
- * Messumformer
- * Fernwirk- Pumpsysteme
- * Messglocken
- * Pneumatische Leitung

- * Verschraubungen für pneumatische Leitung
- * Schwimmschalter
- * Tauchsensoren
- * Ultraschallsensoren
- * Stabsonden
- * Druckschalter
- * Anzeiger, elektrisch, mechanisch
- * Kompressoren, Einperltechnik

- * Schaltanlagenbau - Automatisierung - Fernwirktechnik
- * Freiluftsäulen komplett bestückt mit PS1.LCD / PS2.LCD
- * Kompaktschaltschrank LCD2 - System Metall
- * GfK- Außenschränke / Leersäulen
- * EVU- Anschlusssäule