

PS2.LCD

Microcontroller, Dual pump control



Options



Optional auch mit Hauptschalter oder externem Motorschutzschalter erhältlich.



Auch komplett fertig montiert.
Freiluftsäule FS-PS2.LCDK



Table of contents

- 1.0 Warning and safety instructions**
 - 1.1 Areas of application
 - 1.2 Personnel Qualifications
 - 1.3 Safety instructions for the operator
 - 1.4 Dangers of non-compliance with safety instructions
 - 1.5 Operating instructions
 - 1.6 Independent modification and replacement part supply
 - 1.7 Unauthorised operating modes
 - 1.8 Transport and storage
 - 2.0 General product description, properties and optional functions**
 - 2.1 Product description
 - 2.2 Features
 - 2.3 Optional functions and/or components
 - 3.0 Configuration, control elements and function display**
 - 3.1 Indicator
 - 3.2 Operating elements
 - 3.3 Function display via light-emitting diodes
 - 3.4 Display
 - 4.0 Configuration menu, images and notes on configuring the parameters**
 - 4.1 Table of possible settings.
 - 4.2 Supplements to the individual items in the configuration menu
 - 5.0 Error reports in the display, potential faults, assistance**
 - 5.1 Table of possible fault messages
 - 5.2 The settings in the menu cannot be changed
 - 6.0 Installation, pneumatic and electrical connection and connection of 3 ~, and 1 ~ motors**
 - 6.1 Installation
 - 6.2 Hose attachment
 - 6.3 Electrical connection power supply and pumps
 - 6.4 Fault signalling outputs
 - 6.5 Input for float switch dry run protection
 - 6.6 Connection examples for the operation of the switching devices with float switches
 - 6.7 External level sensor 4 - 20 mA
 - 6.8 Analogue outputs
 - 6.9 Network-independent alarm
 - 7.0 Test mode without pumps**
 - 7.1 To test the control system without the pumps, please note the following
 - 8.0 Technical data**
 - 9.0 Norms**
 - 10.0 Annex: Terminal connection diagrams, bore pattern, note for the lid and section cover**
- Last update: 16/07/2015

1.0 Warnings and Safety information for installing and initiating the control unit

1.1 Area of Application

The switchgear is designed for use in domestic and municipal sewage, waste water and rainwater pump stations.



For activating pumps that run in an Ex-area, the following needs to be considered: The control unit itself has to be mounted outside of the Ex-area.

When using external 4-20 mA level detectors and floating switches that are mounted in the Ex-area, you have to utilize components with according approvals.

When connecting three phase current motors the following limiting values **always** have to be adhered to when setting the electric motor current limit, as well as for settings of mechanic motor protection switches.

Standard Model



	5,5 KW Contactor
Three phase current 400 V	Max. 12 A
Alternating current 230 V	Max. 14,5 A

1.2 Qualification of personnel

The personnel for installing, initiating, and maintaining the control unit has to hold according qualifications for this work.

1.3 Safety information for the operator

The existing safety rules and risk management plans of local energy supply companies should be followed. When opening the unit (Taking the safety screen or a cover off) or when working at the pump the power to the control unit needs to be completely shut off through an external pre-fuse or a separate main switch.

1.4 Hazards if safety information is neglected

Neglecting safety information will endanger people and product/ unit. When neglecting safety information you are subject to lose any entitlement to damages.

1.5 Operating manual

For the installation, initiation, and maintenance of the control unit the operating manual has to be followed. Adhering to the limiting values found in the manual is absolutely necessary.



A circuit protection to the mains of max. 3 x 25 A needs to be installed

1.6 Arbitrary modification and supply with replacement parts

Modifications of the product are only authorized if cleared with the manufacturer in advance. Original parts and accessories authorized by the manufacturer serve safety purposes. Using different parts may waive manufacturer's liability for possible consequences.

1.7 Prohibited operations

The safety of operation of the delivered product can only be granted when the product is used appropriately according to paragraph 1.1 of the operating manual. The limiting values given in technical values have to be adhered to in any case.

1.8 Transport and storage

The control unit needs to be stored and transported avoiding damage by blows, crush, and temperatures outside the realm of -20°C to $+60^{\circ}\text{C}$.

2.0 General product specifications, characteristics, and optional modes of operation

2.1 Product specifications

The pump control unit PS2 - LCD is utilized for automatic level control/regulation of liquid levels. The liquid level is alternatively determined by impact pressure, supply of air, an external sensor (4-20 mA), or floating switch. The motor contactor directly triggers two pumps up to max. 5,5 KW rated power. Additionally, there are 5 relay contacts available to display fault reports. Operation and adjustment are fairly easy. Control settings, times, and motor current limit will be adjusted by a digital potentiometer. All values can be checked on the LC – display. LED's signal operational status and fault messages. Push buttons for the functions **Hand – 0 – Auto** are available as well.

2.2 Characteristics

- LCD plain text display
- Hand - 0 - Auto functions
- Acknowledgment button
- Control of operating time
- Thermal and electrical control of the pump
- Deactivation of pump through stop level and stop delay.
- Electrical control of motor current
- Control for rotating field- und phase cancellation (to be activated in the menu)
- Variable interval start-delay
- Forced activation of pump
- Internal acoustic alarm
- High-water alarm voltage free
- Operating hour meter
- Alternation of pumps
- High stability
- Atex - Mode
- When running in manual mode the pump shuts down automatically after 2 minutes
- Determination of level is achieved alternatively through internal pressure converter, external 4 – 20 mA detector, or floating switch.
- Connection to remote-control system through digital and analog plug-ins and outlets
- All settings and fault reports will stay available after a power outage
- Control for rotating field- und phase cancellation (to be activated in the menu)
- Ability to select the measuring range of the external 4 – 20 mA level detector between 0 – 12,50 m
- Collective fault report voltage free and non-isolated 230VAC
- Memory amount of pump activations
- Amperemeter
- Forced Alternation
- Simple operation
- Service – Mode

NEW! New included in delivery!

- Connection for floating switch dry run protection
- Analog outlets 0-10 V and 4 – 20 mA
- Monitor for operating time
- Fault memory stores the last 4 faults
- Automatic display illumination switch off (after 2 minutes) can be disabled.

2.3 **Optional functions/ components**

(Only included in delivery if explicitly stated in your order)

- External interlock (In this case, the dry run protection is omitted)
- Ability to select Interpump Delay over the menu (activation of pumps is delayed)
- The display indicates maintenance
- Integrated main switch
- Integrated mechanical switch for motor protection
- Additional pressure sensor for redundant high water alarm with activation of the pump

3.0 Adjustment, operational elements and functional displays

3.1 By turning the digital potentiometer "Anzeige", all values and settings can be checked. If a setting needs to be adjusted, the potentiometer has to be turned until the display shows the desired setting. Now the button "Auswahl/Quittung" needs to be pressed. The value saved last will start to flash. Settings may be changed by the potentiometer. Turning fast will cause greater changes of the values, turning slowly allows for precise adjustments. Once the desired value is attained, it needs to be confirmed with the button "Auswahl/ Quittung". The value stops flashing and is saved. All values need to be checked once before the initial start-up. After 20 seconds, the display automatically switches back to the initial setting.

CAUTION! The hours of operation are accounted for continuously. Changing or resetting them is not possible.

3.2 Operational elements

-Digital Potentiometer "Anzeige" By activating the digital potentiometer, all settings as well as fault messages, hours of operation, number of pump activations, and motor current can be checked. Additionally, the settings are adjusted with the digital potentiometer. If the turning knob has not been activated for more than 20 seconds the display will return to the initial setting. (Compare to 3.1 Settings)

-Button Auswahl/Quittung By pressing the button the malfunctions Overload, P1 – P2 pump off, and Thermal Fault 2 will be confirmed after the cause has been eliminated. In case a malfunction still remains active, only the overall-fault-message-relay and the piezo-buzzer will be turned off. This is also the case for thermal fault 1 and high-water alarm. Additionally, settings can be changed via this button (compare to 3.0 Settings).

The following buttons and LEDs are available once for each pump



- HAND By pressing this button the pump is activated in manual mode. The green LED flashes
If the pump runs in manual mode, the pump will automatically shut off after 2 minutes.
- 0 The pump is deactivated
The green LED is off
- AUTO The pump will be activated by the level
The green LED shows a continuous light.

CAUTION! After having interrupted the current in manual mode (HAND) the control unit will switch to automatic mode. The modes of operation "AUTO" and "0" remain saved even in case of power outage (a current interruption).

3.3 Display of Function by LEDs

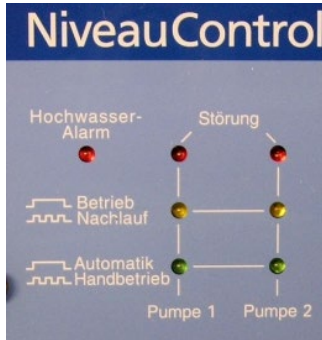

- LED – red = High-water alarm, fault P1 or P2
- LED – yellow continuous light = the pump is operating
- LED – yellow flashing = the pump is operating in “stop delay” mode
- LED – green continuous light = Operates in automatic mode
- LED – green flashing = Operates in manual mode
- LED – green irregularly flashing = Manual mode has turned off after 2 min

3.4 Display

In the first line, the level will be displayed at all times. In the lower lines hours of operation are displayed as long as the pumps have not been activated. If at least one of the pumps operate, the motor current for each pump will be displayed. In case any malfunctions have occurred, they will appear alternately in the lower line of the display.

Automatic background lighting switch off:

If no further settings are actuated on the device, the background lighting switches off automatically after 2 minutes. As soon as the rotary switch or one of the push-buttons is activated, the background lighting switches back on again. This function can be disabled via the menu.

4.0 Settings menu

4.1 The following chart shows different options for settings. The option will appear in the upper line of the display while the lower line will show the value to be changed.

1st line of display	Settings	Explanation
<i>Last Failure</i>	Delete value	The last malfunction will be saved even in case of power-disconnection and can be deleted by pushing the button "Quittung"
<i>Level start</i>	0 – 200 (500) cm	The value determines the start level of the first pump
<i>Level stop</i>	0 – 200 (500) cm	The value determines the stop level of the first
<i>Peak level start</i>	0 – 200 (500) cm	The value determines the start level of the second
<i>Peak level stop</i>	0 – 200 (500) cm	The value determines the stop level of the second pump
<i>High water level</i>	0 – 200 (500) cm	When the set value is exceeded, the overall failure relay and the high-water relay are activated
<i>Runtime limit</i>	0 – 60 Min.	The value 0 deactivates this function. If the value is set between 1-60 min. the pump shuts off if the set operating time has been exceeded without interruption
<i>Pump monitoring</i>	Is deactivated 1 – 60 min	When the set value is exceeded while running in primary load mode (level start/stop) the pumps will alternate
<i>Start Delay</i>	0 – 900 sec.	After a power outage the pump will only start after the pre-set time is over. The display will show the remaining time.
<i>Stop Delay</i>	0 – 180 sec.	After the Stop level is reached, the pump will keep running until the pre-set time is over.
<i>Current limit – 1</i>	0.3 – 14.0 A	If pump 1 exceeds the set power intake for a certain time, it shuts off. The display shows the message P1: Overload. The pump will only be re-activated after the button "Quittung" has been pressed
<i>Current limit – 2</i>	0.3 – 14.0 A	If pump 2 exceeds the set power intake for a certain time, it shuts off. The display shows the message P2: Overload. The pump will only be re-activated after the button "Quittung" has been pressed
<i>Force activation</i>	Is deactivated, 1 – 10 sec.	Is activated = If the pumps have not been activated for 24 hrs, it runs automatically for the duration of the set time.
<i>Acoustic alarm</i>	Is deactivated, Is activated	Is activated = In case of a malfunction the internal piezo-buzzer will sound
<i>Interval – alarm</i>	Is deactivated, Is activated	Is activated = The fault information-relay will be synchronized Instead of a flashing light it is possible to use a more economic steady burning light
<i>Pump - alternation</i>	Is deactivated, Is activated	Is activated = Every time after the primary load pump has run, the pumps will alternate.
<i>P1: Therm. fault 1</i>	Is deactivated, Is activated	Is deactivated = There is no bimetallic contact (alarm contact) connected to terminal 31, 32 (Pump 1)
<i>P2: Therm. fault 1</i>	Is deactivated, Is activated	Is deactivated = There is no bimetallic contact (alarm contact) connected to terminal 38, 39 (Pump 2)
<i>Rot. field fault</i>	Is deactivated Is activated	Is activated = in case the phase sequence is wrong or if L2/L3 have been missed an alarm will be triggered and the pumps cannot be activated.
<i>Light autom. Off</i>	Is shut off, Is activated	If no further settings are actuated on the device, the background lighting switches off automatically after 2 minutes.
<i>ATEX – Mode</i>	Is deactivated, Is activated	Is activated = If no liquid can be measured by the level detector the pumps cannot be activated. This is valid for the "Hand" (=manual) mode as well as the Forced activation and the remote-control systems.
<i>Service – Mode</i>	Is activated Is deactivated	Is activated = All settings can be adjusted Is deactivated = Settings are shown but cannot be adjusted
<i>Level – Control</i>	Internal converter Floating switch 4 – 20 mA Interface	Determination of level by impact pressure or air supply. Determination of level by floating switch Determination of level by external sensor (4 – 20 mA)
<i>20mA => Level</i>	0 – 1000 cm	The effective range of the external level detector can be adjusted
<i>Language</i>	de-en-fr-it-es-pt-nl-no-pl-cz	The displayed language can be adjusted

4.2 Additions to individual bullets of the settings menu

Adjustment of control settings

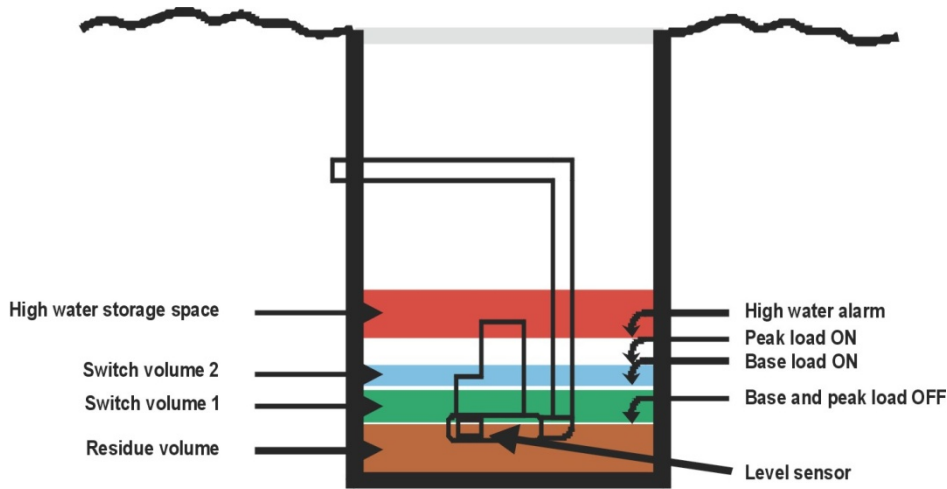

Block operation in peak load

In order to exclusively operate the pumps in alternating mode the start level for the operation in peak load needs to be set to Zero. The display will show „peak load ON is deactivated“.

Minimal level settings (On/Off)

If the start level is chosen to be smaller than 5 cm, the software will automatically use 5 cm as start level. If a stop level is chosen to be smaller than 3 cm, the software will automatically use 3 cm as stop level. In addition, the stop delay time will then begin at 3 cm. This is necessary in order to safely operate the control unit.

NEW! Runtime limit

In the menu the bullet "Runtime limit" may be selected. In delivery condition this value is set to 0, which means the function is deactivated. If a value between 1 – 60 minutes is set, the pump will automatically shut off if it has run without any interruptions for longer than the set value. Additionally, an alarm is triggered and a fault report will appear on the display. The pump will only resume operation once the malfunction has been confirmed (**Quittung**). Runtime limit is used for automatic and manual mode (**Auto** and **Hand**)

Pump monitoring

A maximum operating time can be set for the primary load pump. After the set time is over an alternation to the other pump takes place. It is required that both pumps are set to automatic mode. After three alternations without interruptions the alarm will additionally be triggered and the display will show „Monitoring alarm“.

Pump Monitoring + Operating Time Monitor

It only makes sense to activate one of these functions at a time. If a time is set for both functions, only the one with the smaller time setting will be carried out.

StartDelay

The pre-set start delay will only be active after a power outage. For all further activations the pumps will start up right away once activated by the level.

Stop Delay

Stop delay will make it possible to pump out below the level detector (for example for impact pressure systems).

Current limit (max. Current - 1, max. Current – 2)

The nominal current of the according pumps can be adjusted directly. The software of the control unit will add a certain percentage to a set value in order to adjust tolerances. The activation will occur according to an I^2 / t function and therefore considers the higher starting current of the pumps.

Th. fault 1, Th. fault2 (available over the menu - once for every pump)

For pumps where the temperature control consists of a single bimetallic contact per pump, the malfunction "thermal fault 1" can be deactivated in the menu. "Thermal fault 2" cannot be deactivated in the menu.

NEW! Fault memory

The last 4 errors that occurred remain safe even with no power and can be called up in the menu under "Last fault".

Caution Last fault 1 is the last fault the occurred. If the last fault 1 is called up in the menu, the last fault can be deleted from the memory with the acknowledgement button.

Rotating field fault

The rotating field monitor monitors the order of phases as well as the absence of a phase. In case of a phase malfunction the pumps are locked, an alarm is triggered, and the display shows the message "Rotating field fault". The rotating field monitor can be activated and deactivated in the menu.

CAUTION! When operating 1~ motors the rotating field monitor has to be deactivated.

Atex – Mode

For application of pumps in the Ex – area the Atex- mode needs to be activated in the menu. The Atex- mode prevents an activation of the pump through the manual mode, the forced activation, or the remote control system as long as the stop level has not been reached. If the pumps are activated over the stop delay mode or manual mode while the stop level is exceeded, it is possible to pump out in order to reach a level below the stop level. After 2 minutes, the manual mode is automatically deactivated. If the Atex- mode prevents the pump from being activated, the display will show the message "ATEX: Level less than stop level".

Service – Mode

In the condition supplied at delivery the service mode is activated, meaning all settings can be adjusted. Deactivating the service mode in the menu makes so settings can only be checked via the digital potentiometer.

CAUTION! While the service mode is deactivated no setting (with the exception of "language") can be adjusted.

Level control

There is a choice whether the control unit should be operated by the internal level sensor (impact pressure, air supply), an external level sensor 4-20 mA, or floating switch.

CAUTION! The terminal for the high-water alarm (terminal 23/24) always remains active and may be used as a redundant monitor. As soon as terminals 23/24 are connected, high-water alarm will be triggered and the pumps are activated in alternating mode. When utilizing external 4-20 mA level detectors and floating switches that are mounted in the Ex-area, components with according approvals need to be used as well.

20 mA =>Level

With this setting the control settings and display of level are synchronized with an externally connected 4-20 mA level detector. The processor re-calculates the incoming signal so the correct level is displayed.

CAUTION! If the effective range of the 4-20 mA sensor has been changed in the menu, the control settings need to be re-adjusted as well because they will have changed with the system. Therefore, the right order would be to first change the effective range of the detector and to adjust the control settings afterwards. For operation in the Ex-zone according regulations have to be obeyed. This means the 4-20 mA detector needs to have the according approvals, and a matching Ex-barrier needs to be used. If the control settings lie outside the set range of the level detector, the message "Please check control settings" will be displayed.

Language

Supplied at delivery are German/English/French/Italian/Spanish/Portuguese/Dutch/Norwegian/Polish/Czech. The language can even be adjusted when the service mode is deactivated.

5.0 Fault messages, possible malfunctions, and solutions

5.1 Fault messages on the Display

Message on Display	Possible cause	Solution
<i>P1: Therm. Fault.1 P2: Therm. Fault.1</i>	The controller contact of the according pump has initiated.	If the pump in use does not come with the required WSK the mode needs to be deactivated in the menu (compare to paragraph 4.2. under Therm. fault 1, Therm. fault 2). Check the pump. If it is plugged, clean out the foreign matter. Check the motor for sufficient cooling (dry run).
<i>P1: Therm. Fault 2 P2: Therm. Fault 2</i>	The limiting contact of the according pump has initiated.	If the pump in use does not have the required TMS, every pump that is used needs to be bridged. (Compare to paragraph 6.3 under thermal motor protection switch). Check the pump. If it is plugged, clean out the foreign matter. Check the motor for sufficient cooling (dry run). After the pump has cooled off press the button "Quittung" in order to unlock the pump.
<i>P1: or P2: pump off</i>	Phase 2 is missing or the control unit is being operated without charge	Check feed-in, pump cables, and pump
<i>P1: or P2: Overload</i>	The motor current is higher than the set current limit	Check functioning of pump/ the current limit setting
<i>High water-alarm</i>	The level has exceeded the high water setting	Check functioning/ high water level setting of pumps
<i>High water switch</i>	Contact for the high water switch closed	Check function of pumps/ floating switch
<i>Monitoring alarm</i>	Triggers after three alternations	Check pumps for functioning/settings for pump monitoring
<i>Reverse signals start/ stop level</i>	The settings for start- and stop level overlap	Check level settings
<i>Reverse signals start/ flood level</i>	The settings for high water alarm and start level overlap	Check level settings
<i>Reverse signal start level/ peak level</i>	The start level for the primary load pump exceeds the start level for the peak level pump	Check level settings
<i>Floating switch malfunction</i>	Check plausibility of floating switches/ the order is wrong	Check functioning and electric connection of floating switch
<i>Interface < 3 mA</i>	Signal of external level detector is smaller than 3 mA	Check level detector, ex-barrier, and electric connections
<i>Check control settings</i>	The measuring range of the external level detector has changed. Control settings lie outside of the measuring range.	Check level settings
<i>Rotating field fault</i>	One or two phases are missing/ the rotating field is wrong	Check whether all three phases are connected and whether the rotating field is correct
<i>ATEX: level less than stop level</i>	The ATEX mode is activated and the level is lower than the stop level of the activated pump	In the Ex area, the level first needs to exceed the stop level of the pumps before these can be activated. If the pumps are not in the Ex area the ATEX mode can be deactivated in the menu

PS 2 – LCD

5.2 The settings in the menu are not adjustable

CAUTION! Check the menu for activation of the service mode

6.0 Installation, electric connection

6.1 Installation

The control unit PS 2 – LCD is placed in a control box that measures 300 x 320 x 152 mm (H x W x D). In order to attach the control box, there are 3 drilled holes. One of them is on the backside as a “keyhole” to hook the screw-head. The other two holes can be found underneath the cover of the terminal box.

6.2 Hose connection

The delivery standard for the hose connection is a screwed hose connection 8/6 mm. As an option the control unit can be delivered with different screwed hose connections. It is also possible to exchange the screwed hose connection later on.

The hose connection needs to have an inside thread G1/8” towards the control unit. When exchanging the hose connection it is important to hold the according nut with a 14 mm wrench. You need to make sure to use an appropriate sealing agent when inserting the screw connection.

6.3 Electric connection power supply and pumps



The electric connection needs to be done by an electrician according to the valid regulations..

A circuit protection to the mains of max. 3x25 A (delay action) needs to be installed.

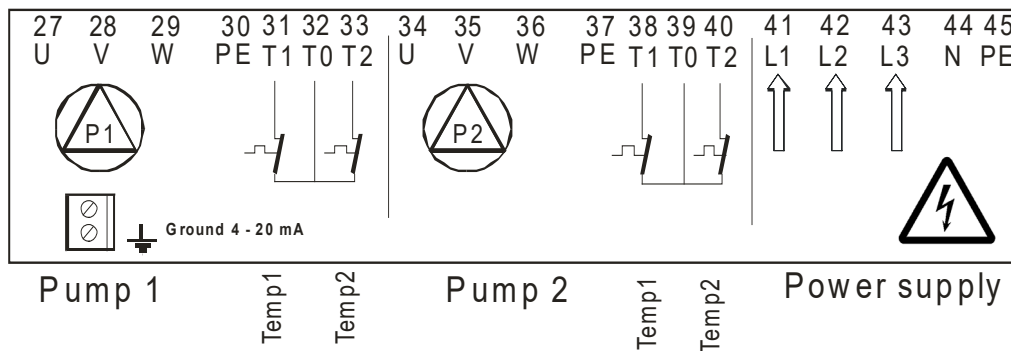

Power supply (3 ~) L1, L2, L3, N, PE (terminal 41, 42, 43, 44, 45) (picture 1a in attachment)

The terminals are designed for a max cable cross sectional area of 4 mm². It is important to make sure a right-sided rotating field is set-up. The terminals are labeled L1, L2, L3, N and PE (41 – 45).

Power supply of the pumps (3~)

The power supply of pump 1 takes place on terminals 27, 28, 29, and 30; they are still labeled with U, V, W, and PE.

The power supply of pump 2 takes place on terminals 34, 35, 36, and 37; they are still labeled with U, V, W und PE.

PS 2 – LCD

**Main connection (1 ~) L1, N, PE (terminals 41, 42, 43, 44, 45)
(Picture 1b in the attachment)**

CAUTION! To operate 1 ~ motors (230V AC) bridges between input terminals L1 (41) to L2 (42), as well as between N (44) and L3 (43) is necessary.
The voltage supply is mounted on terminal L1 (41) and the neutral wire on terminal N (44).

Voltage supply of pumps (1~)

The connection of pump 1 takes place on terminals V (28) and W (29); connection of pump 2 on V (35) and W (36). The protective earth conductors are accordingly connected to the remaining PE terminals (30, 37).

Thermal motor protection switches

Pump 1: Warning contact (Temp 1) Terminal 31/32
(The pump is unlocked automatically after having cooled off.)
Limiting contact (Temp 2) Terminal 32/33
(The pump is unlocked after pushing the button "Quittung")

If not using Temp. 1, the mode needs to be deactivated in the menu. (Seeparagraph4.2).
If not using Temp. 2, a wire jumper between terminal 32 and 33 needs to be put in place.

Pump 2: Warningl contact (Temp 1) Terminal 38/39
(The pump is unlocked automatically after having cooled off)
Limiting contact (Temp 2) terminal 39/40
(The pump is unlocked after pushing the button "Quittung")

If not using Temp. 1, the mode needs to be deactivated in the menu. (See paragraph 4.2).
If not using Temp. 2, a wire jumper between terminal 39 and 40 needs to be put in place.
For pumps in which the bimetallic contact is connected in such a way so it will directly interrupt the current of the pump, the message "**Pump Off**" will appear once the bimetallic contact triggers. The pump will only resume operation once the fault report is confirmed (**Quittung**)

6.4 - 8 Electric connection of the fault terminals and signal inlets (picture 2 attachment)

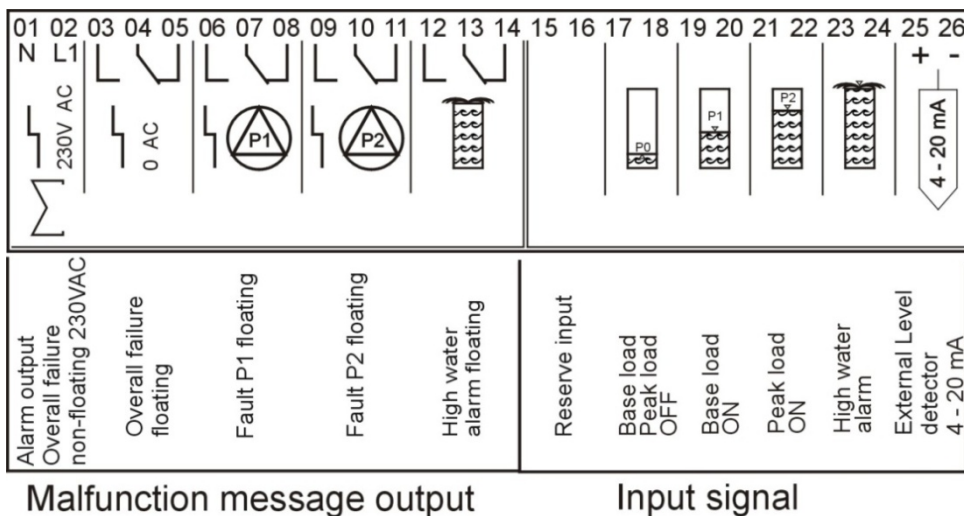

PS 2 – LCD

6.4 Fault terminals

CAUTION! Terminal 01/ 02 Alarm output Overall failure non isolated 230V AC

Terminal 01	N connected
Terminal 02	in case of an alarm L1 (internal delay fuse with 1A)

Terminal 03 / 04 / 05 Overall failure voltage free

If „Intervall Alarm“ is activated in the menu, the relay is synchronized so a more economic steady bulb can be used instead of the flashing bulb.

Terminal 06 / 07 / 08 Fault P1 voltage free

Terminal 09 / 10 / 11 Fault P2 voltage free

Terminal 12 / 13 / 14 High water alarm voltage free

6.5 Port for floating switch and dry run protection

Terminal 15 /16 = dry run protection

Polarity of terminals: 15 = Plus and 16 = Minus

If a floating switch is connected to terminals 15/16, surfacing of the blade wheel and cutting unit from the medium can be prevented.

The dry run protection is active in automatic and manual mode.

When used in the EX-area, according regulations need to be obeyed.

This port can optionally be used to lock the unit if a special program has been agreed upon.

6.6 Examples for connection when operating the control unit via floating switches

The display shows which switch is closed. The use of Normally Opens is mandatory at all times. "Floating Switch" needs to be chosen in the menu under "Level Control"



When used in the EX-area, according regulations need to be obeyed.

PS 2 – LCD

6.7 External Level sensor 4 – 20 mA

“4 - 20 mA Interface“needs to be selected in the menu under “Level Control“

An external Sensor dual conductor system 4 – 20 mA may be connected to terminals 25 and 26 . If used in the Ex-zone according regulations need to be obeyed.

The detector is supplied with a stabilized DC voltage of approximately 24 Volts. At delivery the effective range of the level detector is set so it matches the effective range of the internal pressure sensor. If connecting a level detector with a different effective range, the according setting needs to be changed in the menu (compare to 4.2).



When used in the Ex – zone according regulations need to be obeyed.

The port for the high water floating switch always remains active, even if a different mode of level determination has been selected. When the high water alarm is triggered, both pumps will be started delayed.

6.8 Analog Outlets

The feeder clamps for the analog outlets are installed under the faceplate and serve as a connection to control systems. The signals change proportionally to the level.

When opening the unit (Taking the safety screen or a cover off) or when working at the pump the power to the control unit needs to be shut off through an external pre-fuse or a separate main switch.

4 – 20 mA = terminals 46 (+) und 47 (-) (resistance max. 250 Ohm)
 0 -10 V = terminals 48 (+) und 49 (-) (load max. of 20 mA)

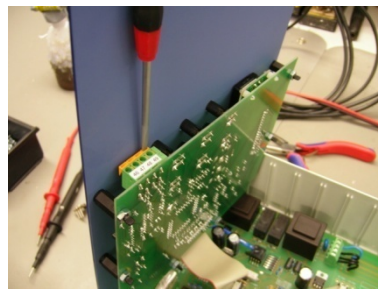
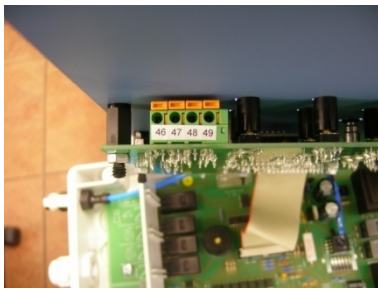

The terminal is prepared for cable cross sections of 0.2 – 0.75 mm (fixed/flexible)

The length for the cable used for analog outlets should not exceed 1.50m

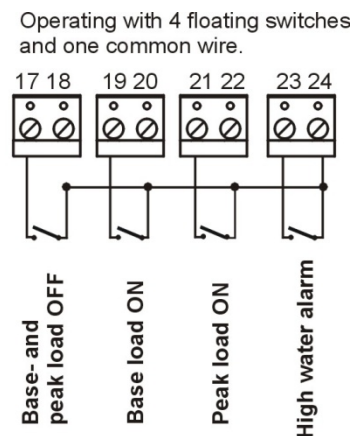
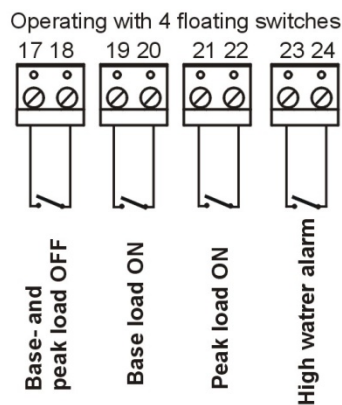
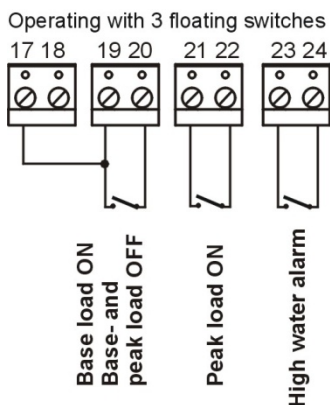

7.0 Trial phase without pumps

7.1 In order to test the control unit without pumps, the following needs to be considered

- It is sufficient to connect N and L1
- Unless the motor current protection is set to 0 A, the message “pump off” will appear.
- Terminal 32 / 33 and 39 / 40 need to be bridged, otherwise the message “Therm. Fault 2” will show on the display.
- Thermal Faults need to be deactivated in the menu for pumps 1 and 2, otherwise the message “Therm. Fault 1” will show on the display.

8.0 Technical data

Operating Voltage:	3 ~400V (L1, L2, L3, N, PE)
Frequency:	50 / 60 Hz
Control voltage:	230V/AC/50/Hz
Power consumption:	max. 20 VA
Max. connected load	P2 < 5,5 KW
Range of elec. motor current protection	0,3 - 14 A

(here the limiting values given in the table 1.1 safety manual have to be adhered to)

Alarm contact 230V	1A
Alarm contact voltage free	3A
Housing:	Polycarbonate
Type of protection:	IP 54
Pressure range (internal sensor):	0 - 2 mWs (0 - 5mWs Option)
Temperature range:	- 20 to + 60 °C
Measurements:	320 x 300 x 120 mm (W x H x D)
Fuse:	5 x 20 1AT (alarm outlet)
Power supply for 4-20 mA detector:	24V/DC

Technical data are always subject to changes!

9.0 Norms:

Applicable EU regulations: 2006/95/EG	EG – Niederspannungrichtlinie (=low voltage directive)
	EG – Richtlinie Elektromagnetische Verträglichkeit (=electromagnetical compatibility) 2004/108/EG

Harmonizing norms in use, particularly:	EN 61000 - 6 - 2: 2005 EN 61000 - 6 - 3:2007 EN 61010 - 1:2001 + Adjustment 1:2002 + Adjustment 2:2004
---	---



Bild 1 a

Connection of 3 ~ motors

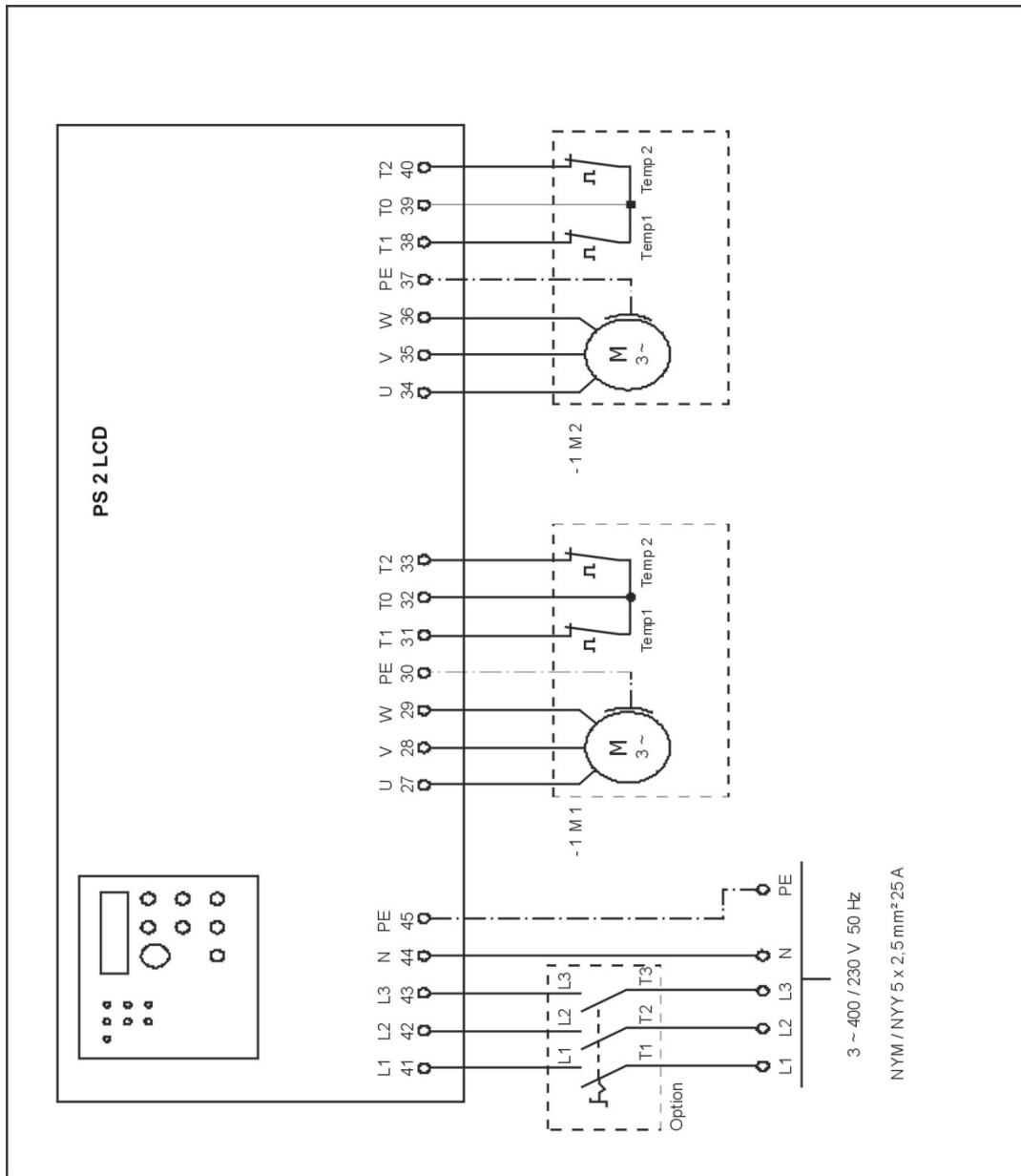

Bild 1 b
 Connection of 1 ~ motors

Caution! When connecting 1~ motors the maximum connected load is 2,4 KW.

Relay outputs and signal inputs

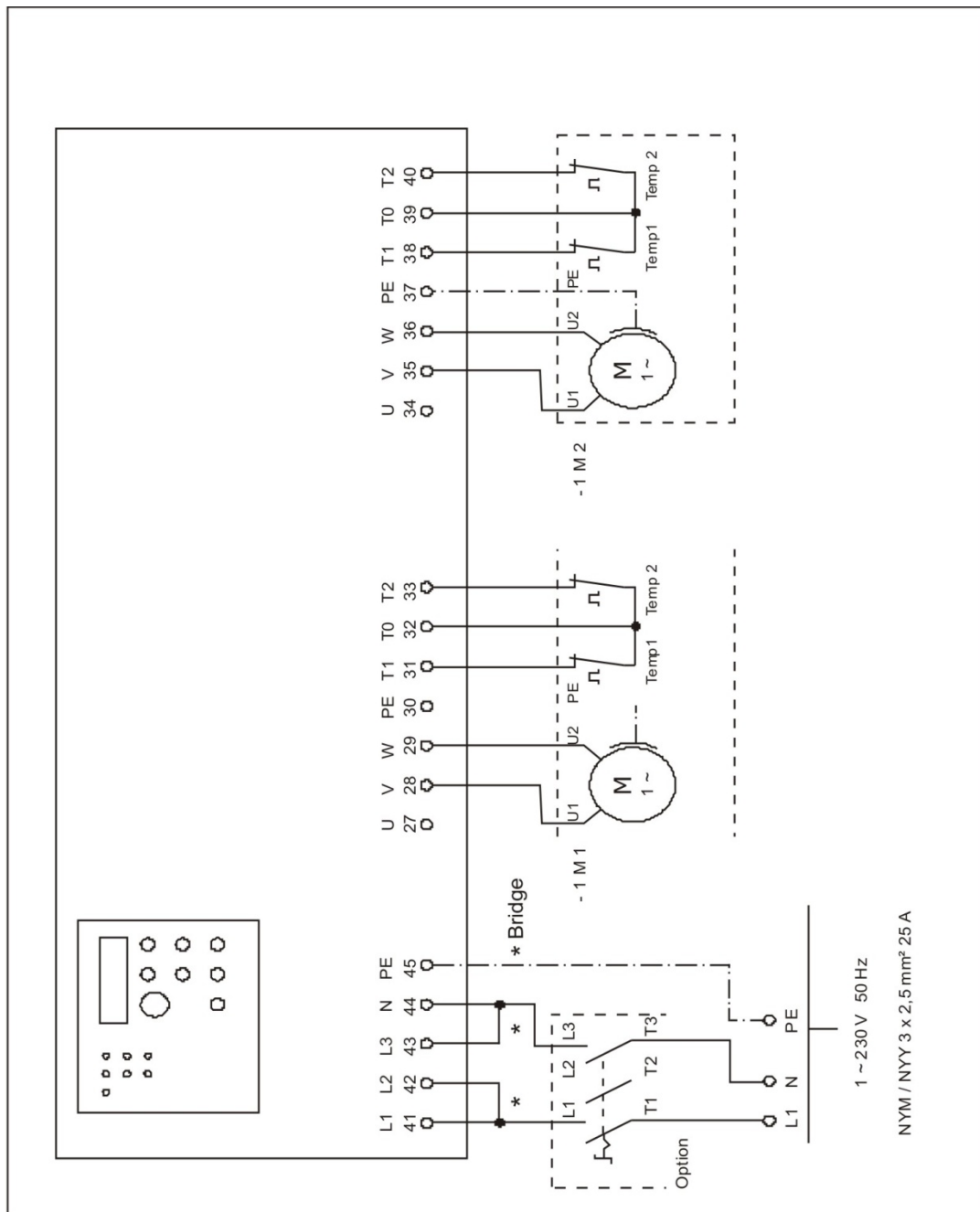

Bild 2

Bore pattern



Note on opening the lid

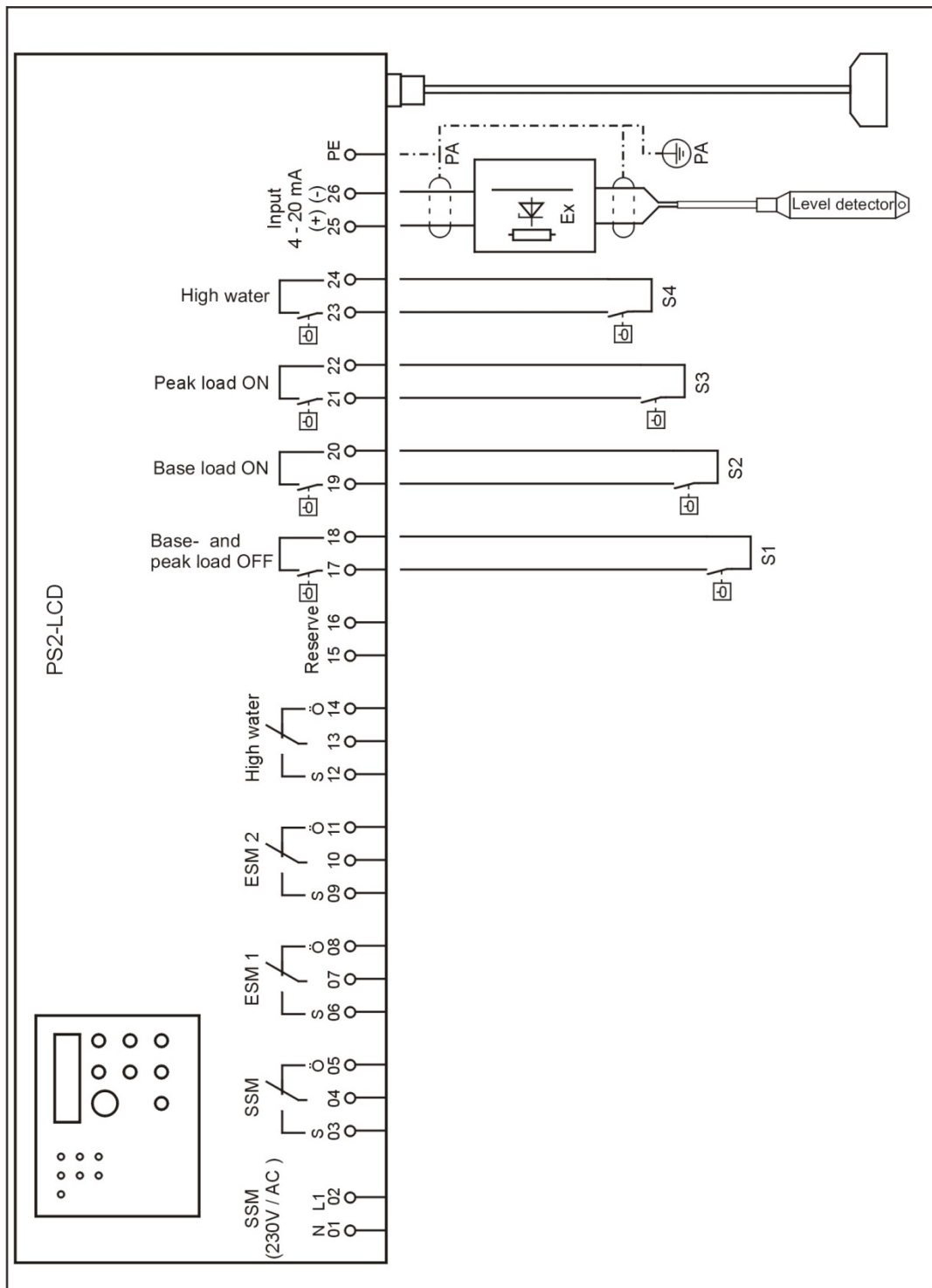
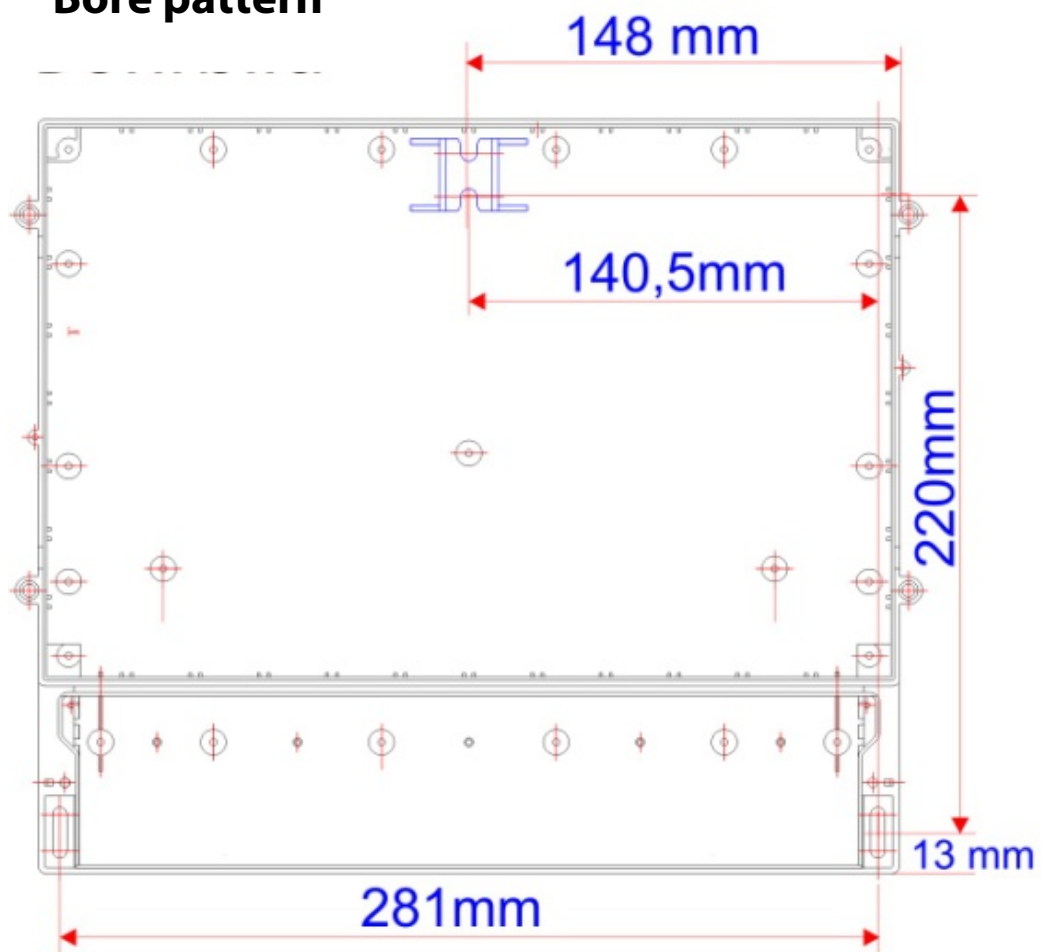
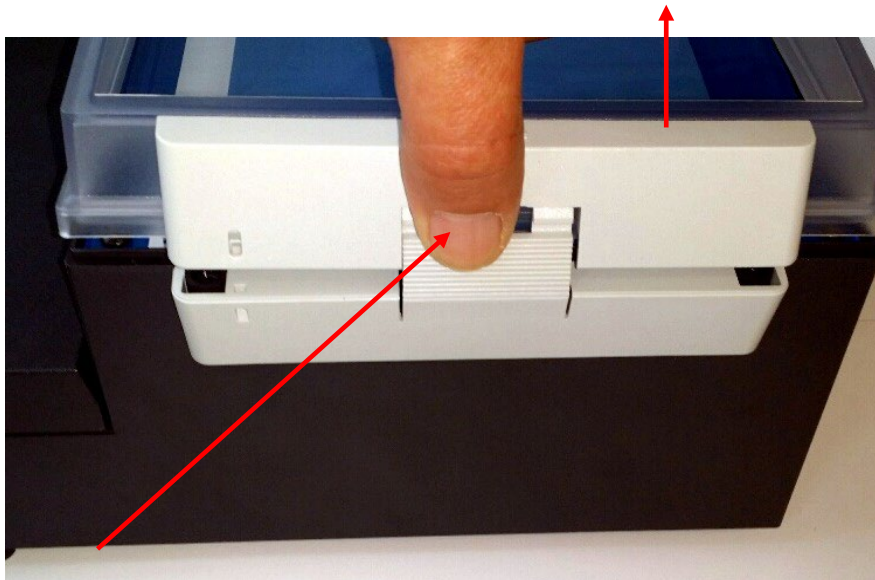

Click here to unhook and then open the lid.

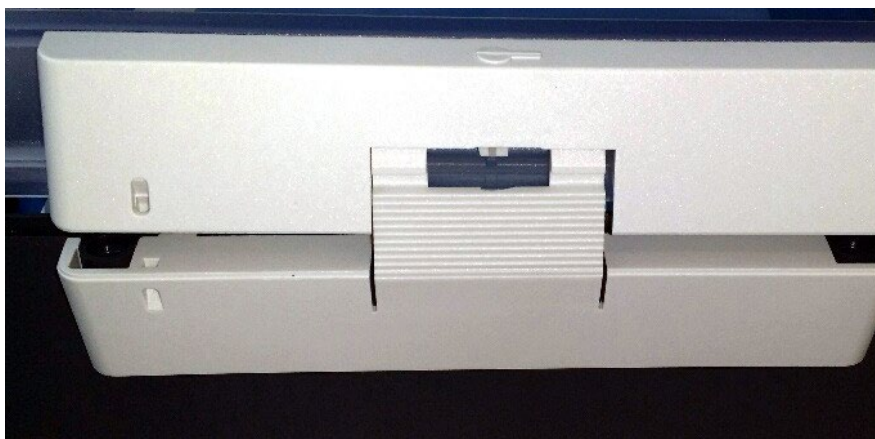

weitere Produkte



PSMEGA1



Messglocke V4A



LESA Micro-Kompakt



PLC TOUCH Grossanlage



LESA- GSM 8



**Kompaktschaltschrank
LCD2 - System Metall**



**Kompaktschaltschrank
mit Noteinspeisung
und EVU-Anschluß**



**PLC TOUCH-System
Kompaktschrank**

- * Pumpensteuerungen
- * Pumpenschaltmodule
- * Alarmmodule
- * GSM-Module
- * Messumformer
- * Fernwirk- Pumpsysteme
- * Messglocken
- * Pneumatische Leitung

- * Verschraubungen für pneumatische Leitung
- * Schwimmschalter
- * Tauchsensoren
- * Ultraschallsensoren
- * Stabsonden
- * Druckschalter
- * Anzeiger, elektrisch, mechanisch
- * Kompressoren, Einperltechnik

- * Schaltanlagenbau - Automatisierung - Fernwirktechnik
- * Freiluftsäulen komplett bestückt mit PS1.LCD / PS2.LCD
- * Kompaktschaltschrank LCD2 - System Metall
- * GfK- Außenschränke / Leersäulen
- * EVU- Anschlusssäule