

## PS1.LCD

Microcontroller, Single pump control



### Options



Optional auch mit Hauptschalter oder externem Motorschutzschalter erhältlich.



Auch komplett fertig montiert.  
Freiluftsäule FS-PS1.LCDK



## Table of contents

- 1.0 Warning and safety instructions**
    - 1.1 Areas of application
    - 1.2 Personnel Qualifications
    - 1.3 Safety instructions for the operator
    - 1.4 Dangers of non-compliance with safety instructions
    - 1.5 Operating instructions
    - 1.6 Independent modification and replacement part supply
    - 1.7 Unauthorised operating modes
    - 1.8 Transport and storage
  
  - 2.0 General product description, properties and optional functions**
    - 2.1 Product description
    - 2.2 Features
    - 2.3 Optional functions and/or components
  
  - 3.0 Configuration, control elements and function display**
    - 3.1 Indicator
    - 3.2 Operating elements
    - 3.3 Function display via light-emitting diodes
    - 3.4 Display
  
  - 4.0 Configuration menu, images and notes on configuring the parameters**
    - 4.1 Table of possible settings.
    - 4.2 Supplements to the individual items in the configuration menu
  
  - 5.0 Error reports in the display, potential faults, assistance**
    - 5.1 Table of possible fault messages
    - 5.2 The settings in the menu cannot be changed
  
  - 6.0 Installation, pneumatic and electrical connection and connection of 3 ~, and 1 ~ motors**
    - 6.1 Installation
    - 6.2 Hose attachment
    - 6.3 Electrical connection power supply and pumps
    - 6.4 Fault signalling outputs
    - 6.5 Input for float switch dry run protection
    - 6.6 Connection examples for the operation of the switching devices with float switches
    - 6.7 External level sensor 4 - 20 mA
    - 6.8 Analogue outputs
    - 6.9 Network-independent alarm
  
  - 7.0 Test mode without pumps**
    - 7.1 To test the control system without the pumps, please note the following
  
  - 8.0 Technical data**
  
  - 9.0 Norms**
  
  - 10.0 Annex: Terminal connection diagrams, bore pattern, note for the lid and section cover**
- Last update: 15/07/2015

## 1.0 Warnings and Safety information for installing and initiating the control unit

### 1.1 Areas of Application

The switchgear is designed for use in domestic and municipal sewage, waste water and rainwater pump stations.



For activating pumps that run in an Ex-area, the following needs to be considered:  
The control unit itself has to be mounted outside of the Ex-area.

When using external 4-20 mA level sensors and floating switches that are mounted in the Ex-area, you have to utilize components with according approvals.

When connecting three phase current motors the following limiting values always have to be adhered to when setting the electric motor current limit, as well as for settings of mechanic motor protection switches.

Standard Model



	5,5 KW Contactor
Three phase current 400 V	Max. 12 A
Alternating current 230 V	Max. 12 A

### 1.2 Qualification of personnel

The personnel for installing, initiating, and maintaining the control unit has to hold according qualifications for this work.

### 1.3 Safety information for the operator

The existing safety rules and risk management plans and local energy supply companies should be followed. When opening the unit (Taking the safety screen or a cover off) or when working at the pump the power to the control unit needs to be shut off through an external pre-fuse or a separate main switch.

### 1.4 Hazards if safety information is neglected

Neglecting safety information will endanger people and product/ unit. When Neglecting safety information you are subject to lose any entitlement to damages.

### 1.5 Operating manual



For the installation, initiation, and maintenance of the control unit the operating manual has to be followed. Adhering to the limiting values found in the manual is absolutely necessary.

A circuit protection to the mains of max. 3 x 16 A needs to be installed.

### 1.6 Arbitrary modification and supply with replacement parts

Modifications of the product are only authorized if cleared with the manufacturer in advance. Original parts and accessories authorized by the manufacturer serve safety purposes. Using different parts may waive manufacturer's liability for possible consequences.

### 1.7 Prohibited operations

The safety of operation of the delivered product can only be granted when the product is used appropriately according to paragraph 1.1 of the operating manual. The limiting values given in technical values have to be adhered to in any case.

### 1.8 Transport and storage

The control unit needs to be stored and transported avoiding damage by blows, crush, and temperatures outside the range of  $-20^{\circ}\text{C}$  to  $+50^{\circ}\text{C}$ .

### 2.0 General product specifications, characteristics, and optional modes of operation

#### 2.1 Product specifications

The pump control unit PS1 - LCD N is utilized for automatic level control/regulation of liquid levels. The liquid level is alternatively determined by impact pressure, supply of air, an external sensor (4-20 mA), or floating switch. The motor contactor directly triggers a pump up to max. 5,5 KW rated power. Additionally, there are 2 relay contacts available to display fault reports. Operation and adjustment are fairly easy. Switching points, times, and motor current limit will be adjusted by a digital potentiometer. All values can be checked on the LC – display. LED's signal operational status and fault messages. Push buttons for the functions Hand – 0 – Auto are still available.

#### 2.2 Characteristics

- LCD plain text display
- Hand - 0 - Auto functions
- Acknowledgment button
- Control of operating time
- Thermal and electrical control of the pump
- Deactivation of pump through stop level and stop delay.
- Electrical control of motor current
- Control for rotating field- und phase cancellation (to be activated in the menu)
- Variable start-delay
- Collective fault signal voltage free and non-isolated 230V~
- Memory amount of pump activations
- Amperemeter
- Simple operation
- Service – Mode
- Forced activation of pump
- Internal acoustic alarm
- High-water alarm
- Operating hour meter
- High stability
- Atex - Mode
- When running in manual mode the pump shuts down automatically after 2 minutes
- Determination of level is achieved alternatively through internal pressure converter, external 4 – 20 mA Level sensor or floating switch.
- Select effective range of the external 4 – 20 mA level sensor over the menu in the range between 0 – 10 m
- Connection to remote-control system through digital and analog plug-ins and outlets
- All settings and fault reports will stay available after a power outage
- All functions of previous versions and terminal connections remain the same
- Reserve inputs for remote action module, timer, or others (will only be included into the program if needed)

**NEW!** NEW included in delivery!

- Input for floating switch dry run protection
- Analog outputs 0-10 V and 4-20 mA
- Fault memory stores the last 4 faults
- Automatic display illumination switch off (after 2 minutes) can be disabled.
- Mains-independent alarm (only for standard version)

#### 2.3 Optional functions and components

(Only included in delivery if explicitly stated in your order)

- External interlock (In this case, the dry run protection is omitted)
- The display indicates maintenance
- Integrated main switch
- Integrated mechanical switch for motor protection
- Additional pressure sensor for redundant high water alarm with activation of the pump.

### 3.0 Adjustment, operational elements and functional displays

**3.1** With the digital potentiometer "Anzeige", all values and settings can be checked. If a setting needs to be adjusted, the potentiometer has to be turned until the display shows the desired setting. Now the button "Auswahl/Quittung" needs to be pressed. The value saved last will start to flash. Settings may be changed by the potentiometer. Turning fast will cause greater changes of the values, turning slowly allows for precise adjustments. Once the desired value is attained, it needs to be confirmed with the button "Auswahl/Quittung". The value stops flashing and is saved. All values need to be checked once before the initial start-up. After 20 seconds, the display automatically switches back to the initial setting.

The hours of operation are accounted for continuously. Changing or resetting them is not possible.

### 3.2 Operational elements

-Digital Potentiometer "Anzeige" By activating the digital potentiometer, all settings as well as fault messages, hours of operation, number of pump activations, and motor current can be checked. Additionally the settings are adjusted with the digital potentiometer. If the turning knob has not been activated for more than 20 seconds the display will return to the initial setting. (Compare to 3.1 Settings)

-Button "Auswahl/Quittung" By pressing the button the malfunctions Overload, Pump Off, and Thermal Fault 2 will be confirmed after the cause has been eliminated. In case a malfunction still remains active, only the collective-fault-message-relay and the piezo-buzzer will be turned off. This is also the case for Thermal Fault 1 and High-water alarm. Additionally, settings can be changed via this button (compare to 3.0 Settings).



- HAND By pressing this button the pump is activated in manual mode. The green LED flashes

**NEW!**

If the pump is activated in manual mode, the pump will automatically shut off after 2 minutes and the green LED will flash irregularly.

- 0 The pump is deactivated The green LED is off.

- AUTO The pump will be activated by the level The green LED shows a continuous green light.

**Attention:** After having interrupted the current in manual mode, the control unit will switch to automatic mode. The modes of operation "AUTO" and "0" remain saved even in case of 0 potential (a current interruption).

### 3.3 Display of Function by LEDs



- LED – red = high-water alarm, malfunction
- LED – yellow continuous light = the pump is operating
- LED – yellow flashing = the pump is operating in stop delay mode
- LED –green continuous light = operates in Automatic mode
- LED –green flashing = operates in manual mode
- LED – green irregular flashing = manual mode has shut off after 2 minutes

### 3.4 Display

In the first line, the level will be displayed at all times. In the lower lines hours of operation are displayed as long as the pump has not been activated. If the pump is operating, the motor current will be displayed. In case any malfunctions have occurred, they will appear alternately in the lower line of the display.

#### Automatic background lighting switch off:

If no further settings are actuated on the device, the background lighting switches off automatically after 2 minutes. As soon as the rotary switch or one of the push-buttons is activated, the background lighting switches back on again. This function can be disabled via the menu.

## 4.0 Settings menu

4.1 The following chart shows different options for settings. The option will appear in the upper line of the display while the lower line will show the value to be changed.

1. line of Display	Option for Setting	Explanation
<i>Last Failure</i>	Delete value	The last malfunction will be saved even in case of power-disconnection and can be deleted by pushing the button "Quittung"
<i>Level Start</i>	0 – 100 (200) cm	The value determines start level of pump
<i>Level Stop</i>	0 – 100 (200) cm	The value determines stop level of pump
<i>High-water level</i>	0 – 100 (200) cm	Once predetermined value is exceeded, the collective fault report relay and the high-water relay are activated
<i>Operating limit</i>	0 – 60 Min.	The value 0 deactivates this function. If the value is set between 1-60 min. the pump shuts off if the set operating time has been exceeded without interruption
<i>Start Delay</i>	0 – 900 sec.	After a power outage the pump will only start after the pre-set time is over. The display will show the remaining time.
<i>Stop Delay</i>	0 – 180 sec.	After the Stop level is reached, the pump will keep running until the pre-set time is over.
<i>Current Limit</i>	0.3 – 16.0 A	If the pump exceeds the set power intake for a certain time, it shuts off. The display shows: Overload. The pump will only be re-activated after the button "Quittung" has been pressed
<i>Force activation</i>	Is deactivated, 0 – 10 sec.	Is activated = If the pump has not been activated for 24 hrs, it will automatically run for duration of the set time.
<i>Acoustic alarm</i>	Is deactivated, Is activated	Is activated = In case of a malfunction the internal piezo-buzzer will sound
<i>Intervall - Alarm</i>	Is deactivated, Is activated	Is activated = The fault information-relay will be synchronized. Instead of a flashing light it is possible to use a more economic steady burning light
<i>Thermal fault 1</i>	Is deactivated, Is activated	Is deactivated = There is no bimetallic contact (alarm contact) connected to terminal 20,21.
<i>Rot. Field fault</i>	Is deactivated, Is activated	Is activated = in case the phase sequence is wrong or if L2/L3 have been missed an alarm will be triggered and the pumps cannot be activated.
<i>Light autom. Off</i>	Is shut off, is activated	If no further settings are actuated on the device, the background lighting switches off automatically after 2 minutes.
<i>ATEX - Mode</i>	Is deactivated, Is activated	Is activated = If no liquid can be measured by the level sensor the pumps cannot be activated. This is valid for the Manual mode as well as the Forced activation and the remote-control systems.
<i>Service - Mode</i>	Is activated, Is deactivated	Is activated = All settings can be adjusted Is deactivated = Settings are shown but cannot be adjusted
<i>Level Control</i>	Intern. converter Floating switch 4 – 20 mA Interface	Determination of level by impact pressure or air supply. Determination of level by floating switch Determination of level by external sensor ( 4 – 20 mA)
<i>20mA =&gt;Level</i>	0 – 1000 cm	The effective range of the external level sensor can be adjusted
<i>Language</i>	German - English	The displayed language can be adjusted



## 4.2 Additions to individual bullets of the settings menu

Adjustment of control settings

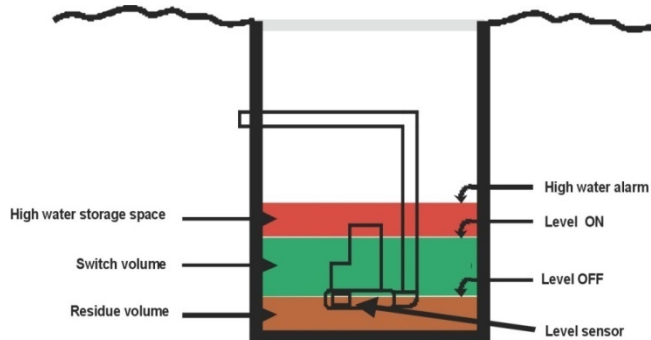

### Start Delay

The pre-set start delay will only be active after a power outage. For all further activations the pumps will start up right away once activated by the level.

### Minimal level settings (On/Off)

If the start level is chosen to be smaller than 5 cm, the software will automatically use 5 cm as start level. If a stop level is chosen to be smaller than 3 cm, the software will automatically use 3 cm as stop level.. In addition, the start of the stop delay time will then begin at 3 cm. This is necessary in order to safely operate the control unit.

### Stop delay

Stop delay will make it possible to pump out below the level sensor (for example for impact pressure systems)

### **NEW!** Monitoring of operating time

The bullet "Operation limit" can be chosen in the menu. In the condition supplied at delivery, the value is set to zero. This means the function is deactivated. If the value is set between 1 – 60 minutes the pump will be deactivated once it ran for longer than the pre-set time without interruption. Additionally, an alarm will be triggered and an according fault report will appear on the display. The pump will only proceed once the fault has been confirmed. The operation time monitoring concerns the automatic mode and the manual mode.

### Current limit (max. current)

The nominal current of the according pumps can be adjusted directly. The software of the control unit will add a certain percentage to a set value in order to adjust tolerances. The activation will occur according to a  $I^2 / t$  function and therefore considers the high starting current of the pump. For pumps where the temperature control consists of a single bimetallic contact, the malfunction "thermal fault 1" can be deactivated in the menu. "Thermal fault 2" cannot be deactivated in the menu.

### **NEW!** Fault memory

The last 4 errors that occurred remain safe even with no power and can be called up in the menu under "Last fault".

**Caution** Last fault 1 is the last fault that occurred. If the last fault 1 is called up in the menu, the last fault can be deleted from the memory with the acknowledgement button.

### **NEW!** Rotating field fault

The rotating field monitor monitors the phase sequence as well as the absence of a phase. In case of a phase malfunction the pumps are locked, an alarm is triggered, and the display shows the message "Rotating field fault". The rotating field monitor can be activated and deactivated in the menu. When operating single phase motors the rotating field monitor has to be deactivated.

### Atex – Mode

For application of pumps in the Ex – area the Atex- mode needs to be activated in the menu. The Atex-mode prevents an activation of the pump through the manual mode, the forced activation, or the remote control system as long as the stop level has not been reached. If the pumps are activated over the stop delay mode or manual mode while the stop level is exceeded, it is possible to pump out in order to reach a level below the stop level. After 2 minutes, the manual mode is automatically deactivated. If the Atex-mode prevents the pump from being activated, the display will show the message "ATEX: Level less than stop level".

### Service – Mode

**ATTENTION!** In the condition supplied at delivery the service mode is activated, meaning all settings can be adjusted. Deactivating the service mode in the menu leads to only being able to check values over the digital potentiometer. While the service mode is deactivated no setting (with the exception of "language") can be adjusted.

### Level Control

There is a choice whether the control unit is operated by the internal level sensor (impact pressure, air supply), an external level sensor 4-20 mA, or a floating switch.

**ATTENTION!** The terminal for the high-water alarm (terminal 16/17) always remains active and may be used as a redundant monitor. As soon as terminals 16/17 are connected, high-water alarm will be triggered and the pump is activated.

When utilizing external 4-20 mA level sensors and floating switches that are mounted in the Ex-area, components with according approvals need to be used as well.

### 20 mA =>Level

This setting causes the control settings and the level display to be aligned with a connected external 4-20 mA level sensor. The processor re-calculates the incoming signal so the correct level is displayed.

**ATTENTION!** If the effective range of the 4-20 mA level sensor has been changed in the menu, the level settings need to be re-adjusted as well because they will have changed with the system. Therefore, the right order would be to first change the effective range of the Level sensor and to adjust the level settings afterwards. For operation in the Ex-zone according regulations have to be obeyed. This means the 4-20 mA level sensor needs to have the according approval and a matching Ex-barrier needs to be used. If the control settings lie outside the set range of the level sensor, the message "Please check control settings" will be displayed.

## Language

Supplied at delivery are German and English. If desired Polish/ Czech/Italian/French can be supplied. The language can even be adjusted when the service mode is deactivated.

## 5.0 Fault messages, possible malfunctions, corrections

### 5.1 Fault messages on the display

Message on Display	Possible cause	Correction
<i>Thermal Fault 1</i>	The controller contact of the according pump initiates.	If the pump in use does not come with the required thermal motor protection contact the mode needs to be deactivated in the menu (compare to 4.2. Thermal Fault 1, Thermal fault 2). Check the pump. If it is plugged, clean out the foreign matter. Check the motor for sufficient cooling (dry run).
<i>Thermal fault 2</i>	The limiting contact of the according pump initiates.	If the pump in use does not have the required thermal motor protection contact every pump that is used needs to be bridged. (compare to 6.3 Thermal motor protection contact). Check the pump. If it is plugged, clean out the foreign matter. Check the motor for sufficient cooling (dry run). After the pump has cooled off, push the button "Quittung" in order to unlock the pump.
<i>Pump off</i>	Phase 2 is missing or the control unit is being operated without charge.	Check feed-in, pump cables, and pump
<i>High-water-Alarm</i>	The level has exceeded the flood setting	Check pump for mode or high-water level
<i>High-waterswitch</i>	Contact for the high-water switch has closed	Check if pump/ floating switch are functioning
<i>Reverse signals start/stop level</i>	The settings for start and stop levels interfere.	Check level settings
<i>Reverse signals start/flood level</i>	The settings for high-water alarm and start level interfere	Check settings for level
<i>Runtime error</i>	Pumps run without interruption for longer than the time set.	Check functioning of pump
<i>Floating switch malfunction</i>	Validation of floating switches, wrong order	Check if floating switch is functioning and check if it is connected to power correctly
<i>Dry run protection activated</i>	Contact for dry run protection has been activated	Check functioning of pump / floating switch
<i>Interface &lt; 3 mA</i>	Signal of external level sensor lower than 3 mA	Check level sensor, Ex-barrier, and electrical connections
<i>Please check control settings</i>	The effective range of the external level sensor has been changed. The level settings lie outside the effective range.	Check settings for level
<i>Rotating field</i>	One or two phases are missing, or rather the rotating field is not correct	Check if all 3 phases are adjacent and if the rotating field is correct.
<i>ATEX: level less than stop level</i>	The ATEX mode has been activated and the level lies below the stop level of the chosen pump.	Before being able to activate the pumps, the level in the Ex-area needs to rise over the stop level of the pump. As long as the pumps are not in the Ex-area, the ATEX mode can be deactivated in the menu.

## 5.2 The settings in the menu cannot be adjusted

**ATTENTION!** Check the menu whether the service-mode is activated

## 6.0 Installation, electrical connection

### 6.1 Installation

The control unit PS1 – LCD N is placed in a control box that measures 290 x 170 x 130mm (H x W x D with bolts and air connection). In order to attach the control box, there are 4 drilled holes.

### 6.2 Hose connection

The delivery standard for the hose connection is a screwed hose connection 8/6 mm. As an option the control unit can be delivered with different screwed hose connections. It is also possible to exchange the screwed hose connection later on. The hose connection needs to have an inside thread G1/8" towards the control unit. When exchanging the hose connection it is important to hold the according nut with a 14 mm wrench. You need to make sure to use an appropriate sealing agent when inserting the screw connection.

### 6.3. Electric connection, power supply, and pumps



The electric connection needs to be installed by an electrician according to the valid regulations.

A circuit protection to the mains of max. 3 x 16 A (delay action) needs to be installed.

#### Terminal connection Power supply

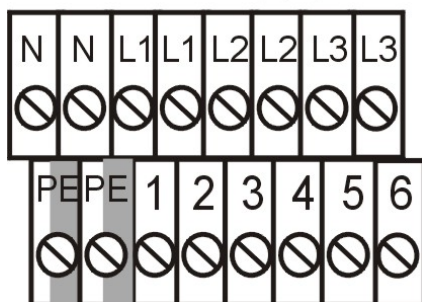

Connection Power supply (3 ~) L1, L2, L3, N, PE (pic 1a in attachment)  
(There is a duplicate to each terminal and they are bridged internally)

The terminals are designed for a max cable cross sectional area of 4 mm<sup>2</sup>. It is important to make sure a right-sided rotating field is set-up. The terminals are labeled L1, L2, L3, N and PE.

### Connection of pump:

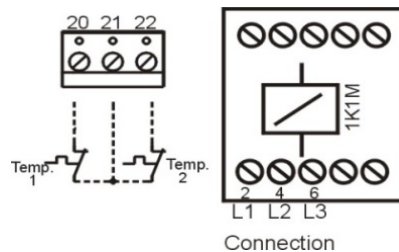

The connections L1 L2 L3 of the pump are directly attached to the motor contactor. The protective earth conductor is connected to the remaining PE terminal.

The bimetallic contact, which unlocks the pump after it has cooled down, needs to be connected to terminal 20/21; the bimetallic contact that unlocks the pump after pressing the “Quittung” button needs to be connected to terminal 21/22 on the upper circuit board. (In case Temp.1 is not being connected, *thermal fault 1* needs to be deactivated in the menu).

**To operate 1 ~ motors (230V AC)** a bridge between input terminal L1 to L2, as well as between N an L3 are necessary.

### Power supply to the pumps (1~)

The connection of the pumps occurs on contactor T2 = L und T3 = N

**ATTENTION!** Because measuring the current needs to happen through T2, the motor needs to be connected at this terminal.

### Thermal motor protection contact

Warning contact                      Temp 1 / Terminal 20/21  
the pump is unlocked automatically after having cooled off.

Limiting contact                      Temp 2 / Terminal 21/22  
The pump is unlocked after pushing the button “Quittung”

If Temp.1 is not used, the mode needs to be deactivated in the menu (compare to 4.2).

If Temp. 2 is not used, a wire jumper needs to be put in place between terminal 21 and 22.

For pumps in which the bimetallic contact is connected in a way so it will directly interrupt the current of the pump, the message “*Pump Off*” will appear once the bimetallic contact triggers. The pump will only resume operation once the fault report is confirmed (*Quittung*).

6.4 - 9 Electric connection of the fault terminals and signal inlets (pic 2 attachment)

6.4 Fault terminals

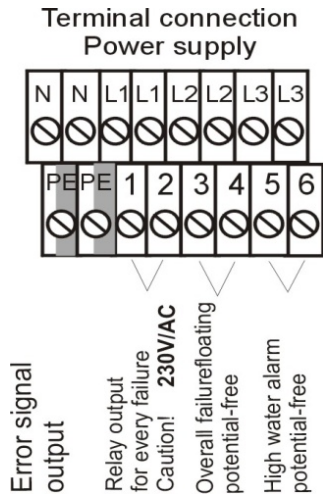

**Caution!** Terminal 1 / 2 = Relay output for every failure non-isolated. In case of an alarm there are 230 V/AC adjacent (this port is protected by a micro-fuse 1 A T).

Terminal 3 / 4 = Overall failure, voltage free, closed in case of alarm (Terminals 1 / 2 and 3 / 4 are active for each failure, even in case of high-water alarm).

Terminal 5 / 6 = High-water alarm, voltage free output, closed in case of alarm

6.5 Port for floating switch dry run protection

Terminal 10/11 = Dry run protection  
Polarity of the terminals: 10 = Plus and 11 = Minus

When connecting a floating switch to terminals 10-11 surfacing of the cutting unit/ blade wheel from the medium can be prevented.

Caution. The Dry run protection is only active in automatic mode.

When used in the Ex-zone, the according regulations need to be obeyed. If a special program has been agreed upon, it is optional to enable this terminal to lock the unit

6.6 Examples for connections when operating the control unit with floating switches

The display shows which switch is closed. The use of a Normally Open is always mandatory. "Floating switch" needs to be selected in the menu under "level control" The port for high water alarm (terminals 16 / 17) always remains active.

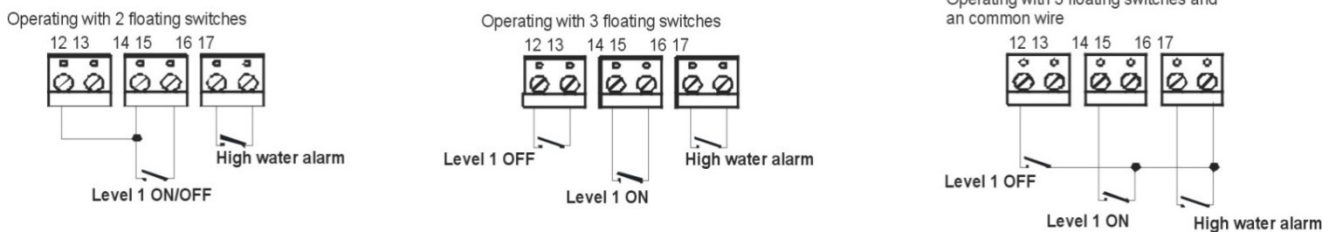

If used in the **Ex-zone** according regulations need to be obeyed.

### 6.7 External level sensor 4 – 20 mA

“4 - 20 mA Interface” needs to be selected under “level control” in the menu. An external sensor dual conductor system 4 – 20 mA may be connected to terminals 34 (-) and 35 (+). The sensor is supplied with a stabilized DC voltage of approximately 20 Volts. At delivery the effective range of the level sensor is set so it matches the effective range of the internal pressure sensor. If connecting a level sensor with a different effective range the according setting needs to be changed in the menu (compare to 4.2). The output is active meaning the control unit supplies the sensor with power.



If used in the Ex-zone according regulations need to be obeyed.

### 6.8 Analog Outlets

Analog outlets are supposed to be used for the connection to control systems. Signals change proportionally to the level.

0 -10 V = Terminal 36 (+) and 37 (-) (load max. of 20 mA)

4 – 20 mA = Terminal 38 (+) and 39 (-) (resistance max. 250 Ohm)

The length for the cable used for analog outlets should not exceed 1.50m

### 6.9 Network-independent alarm:

(Only with the standard version)

This function is omitted with the optional versions with 2 sensors, motor circuit breaker or main switch. With the use of a rechargeable battery a network-independent alarm signal can be sounded in the event of a power failure. The alarm issued is a constant acoustic signal.

Ensure correct polarity when inserting the rechargeable battery!

In order to ensure faultless functionality, the rechargeable battery must be fully charged before insertion, or charged for 24h in the switchgear.



#### Attention!

**Never** use non-rechargeable batteries.

The following rechargeable batteries are approved for use:

Nickel-metal hydride rechargeable battery (**NiMH**)

Nickel-cadmium rechargeable battery (**NiCd**)

## 7.0 Trial phase without pump

### 7.1 In order to test the control unit without pumps the following needs to be considered

- It is sufficient to connect N1 and L1
- Unless the motor current protection is set to 0 A, the message “L pump off” will appear
- Terminals 21 / 22 need to be bridged, otherwise the message “Thermal Fault 2” will appear.
- Thermal fault 1 need to be deactivated in the settings menu, otherwise the message “Thermal Fault 1” will appear.

## 8.0 Technical data

Operating Voltage :	3 ~ 400V (L1, L2, L3, N, PE)
Frequency:	50 / 60 Hz
Control voltage:	230V / AC
Power consumption:	max. 10 VA
Max. connected load:	P2 < 5,5 KW
Range of electr. motor protection:	0,3 - 16 A
Alarm contact 230V:	1 A
Alarm contact voltage free:	3 A
Housing:	Polycarbonat
Type of protection:	IP 54
Pressure range (internal sensor):	0 - 1 mWs (0 - 2mWs option)
Temperature range:	- 20 to + 60 °C
Measurements:	170 x 290 x 130 mm (W x H x D) Measurements with cable connection and air supply
Fuse:	5 x 20 1AT (alarm outlet)
Power supply for 4-20 mA Level sensor:	20V / DC
cable connections:	2 x M25 x 1,5 1 x M16 x 1,5
Hose connection:	6/8 mm (If desired, different hose connections can be delivered).

Technical Data always remain subject to change!

## 9.0 Norms

Applicable EU regulations:	EG – low voltage directive 2006/95/EG
	EG – electromagnetical compatibility 2004/108/EG
Harmonizing norms in use, particularly:	EN 61000 - 6 - 2: 2005 EN 61000 - 6 - 3:2007 EN 61010 - 1:2001 + Update 1:2002 + Update 2:2004



10.0 Annex:

Terminal connection of 3~ motors

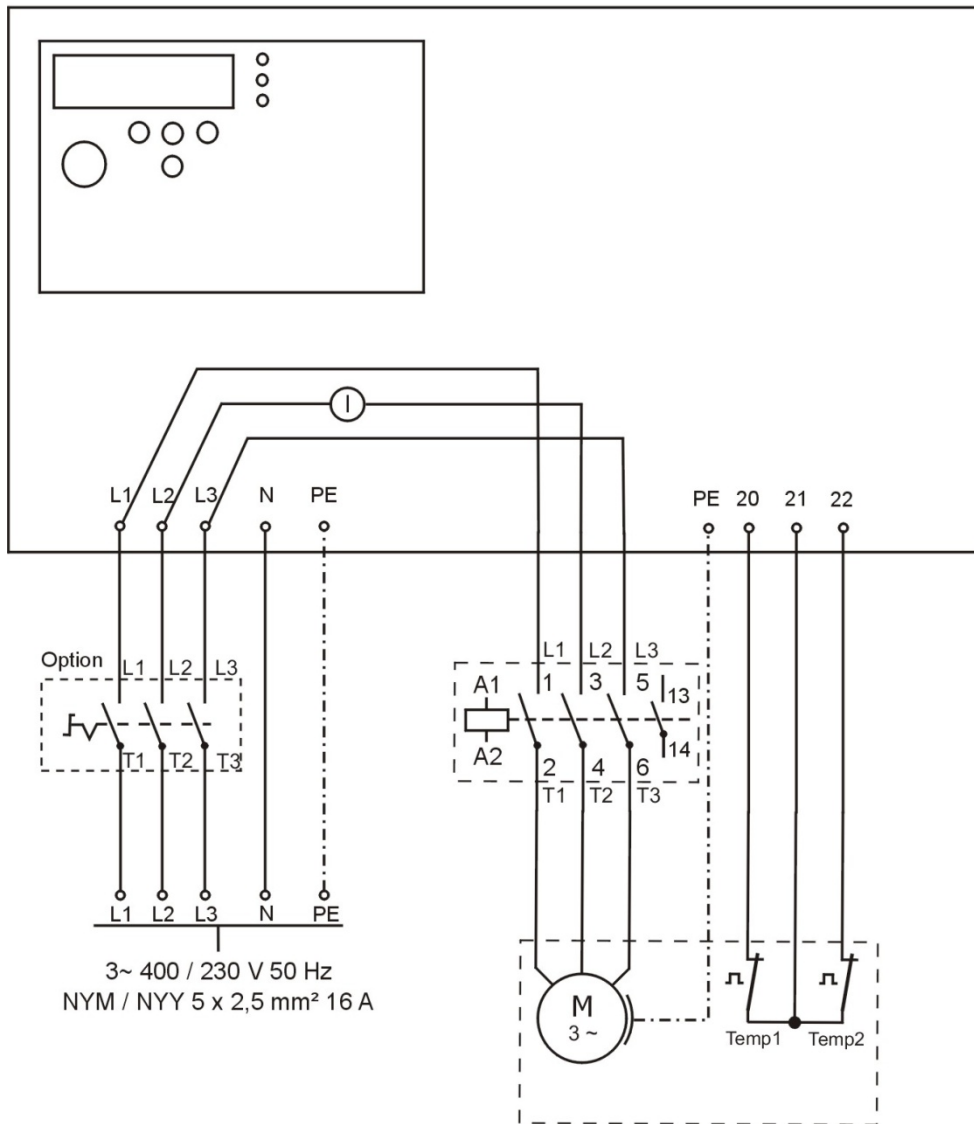

Terminal connection of 1~ motor

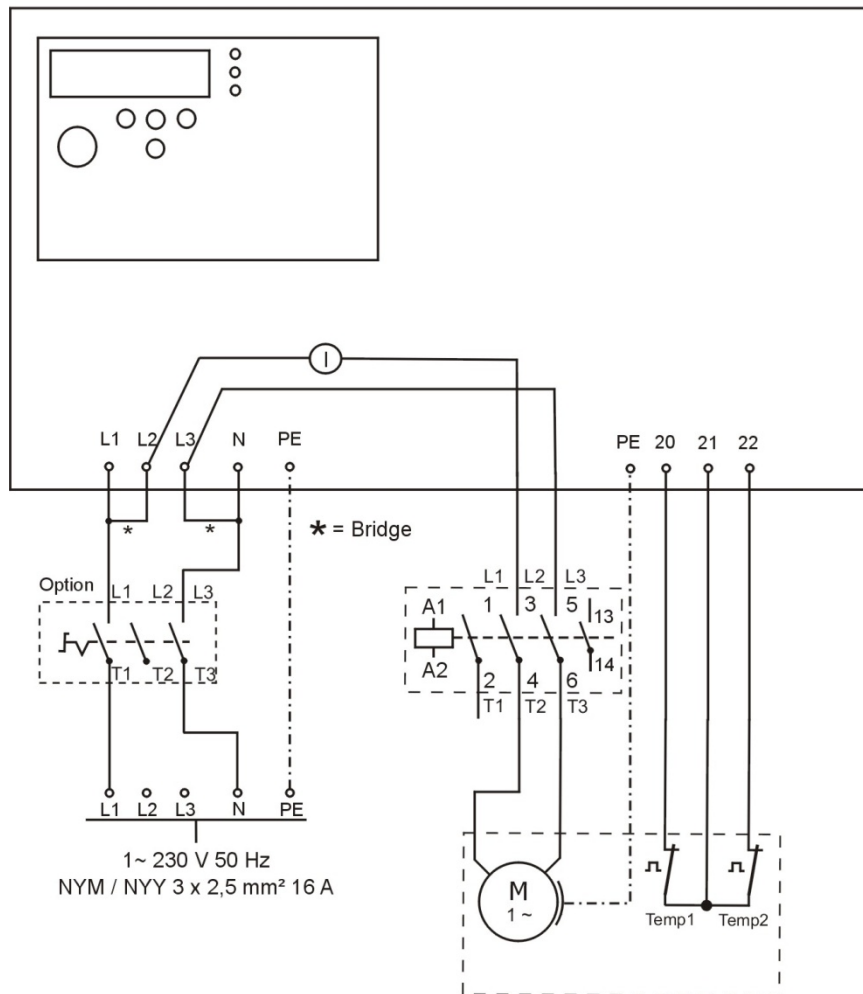

**Caution!** When connecting 1~ motors the maximum connected load is 2,4 KW.

Relay output, signal output, analog output

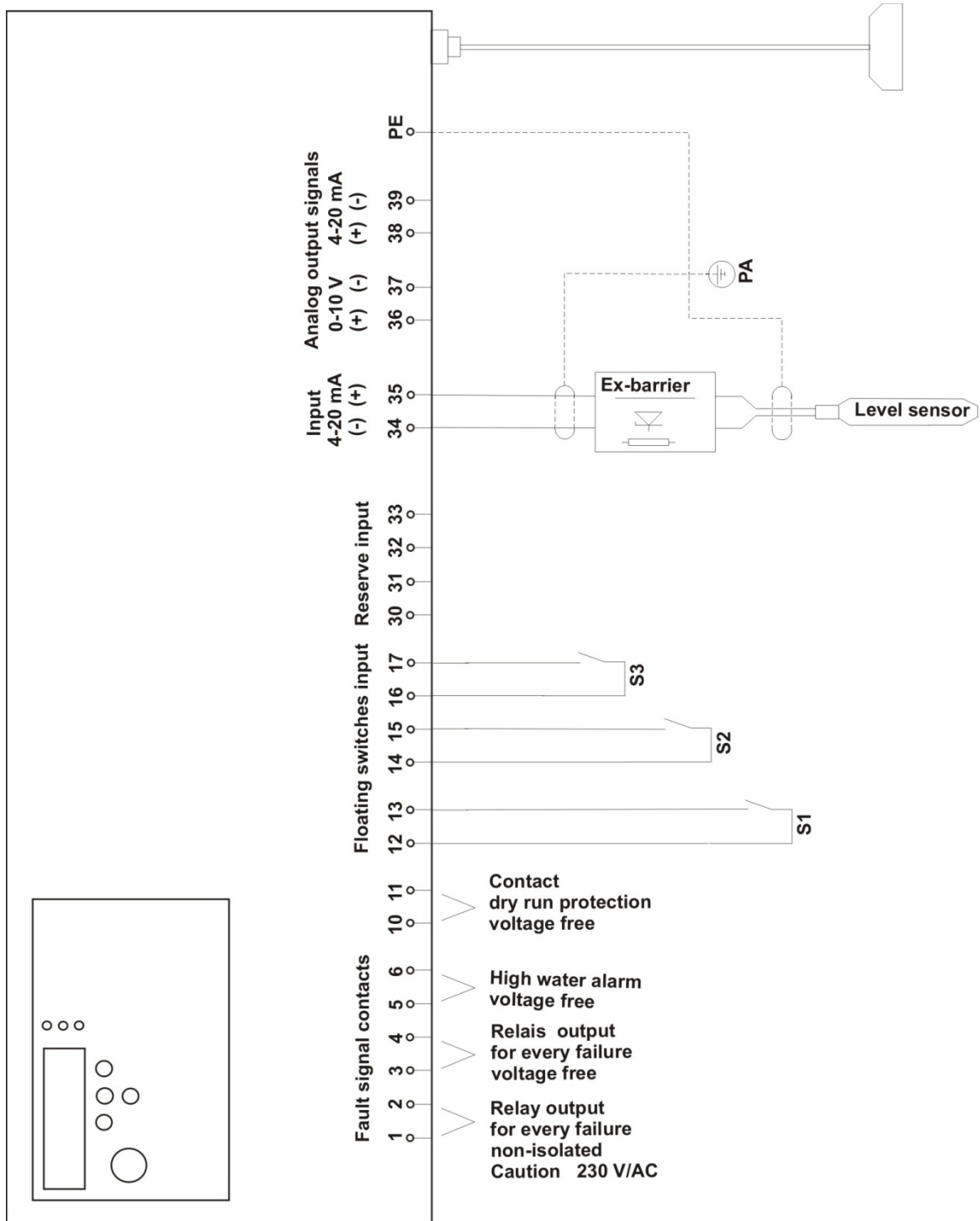

### Bore pattern

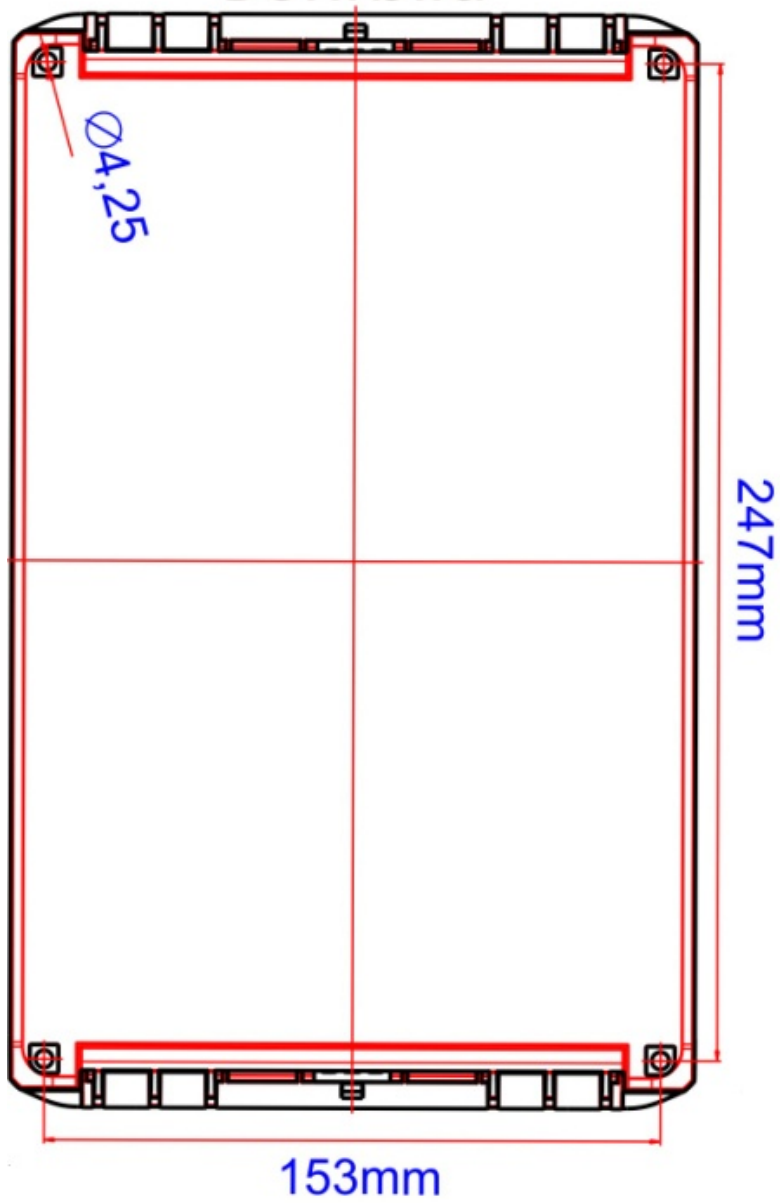

### Note on opening the lid

1. Push the grey side part upwards.



2. The lid can now be opened forwards.



By loosening both grey side parts the lid can be completely removed.

## weitere Produkte



**PSMEGA1**



**Messglocke V4A**



**LESA Micro-Kompakt**



**PLC TOUCH Grossanlage**



**LESA- GSM 8**



**Kompaktschaltschrank  
LCD2 - System Metall**



**Kompaktschaltschrank  
mit Noteinspeisung  
und EVU-Anschluß**



**PLC TOUCH-System  
Kompaktschrank**

- \* Pumpensteuerungen
- \* Pumpenschaltmodule
- \* Alarmmodule
- \* GSM-Module
- \* Messumformer
- \* Fernwirk- Pumpsysteme
- \* Messglocken
- \* Pneumatische Leitung

- \* Verschraubungen für pneumatische Leitung
- \* Schwimmschalter
- \* Tauchsensoren
- \* Ultraschallsensoren
- \* Stabsonden
- \* Druckschalter
- \* Anzeiger, elektrisch, mechanisch
- \* Kompressoren, Einperltechnik

- \* Schaltanlagenbau - Automatisierung - Fernwirktechnik
- \* Freiluftsäulen komplett bestückt mit PS1.LCD / PS2.LCD
- \* Kompaktschaltschrank LCD2 - System Metall
- \* GfK- Außenschränke / Leersäulen
- \* EVU- Anschlusssäule